

AUTOMOTIVE MEGATRENDS

Magazine | Q1 2015



The Powertrain Innovation Issue



#ConnectedCar #FreightEfficiency #eMobility
#Manufacturing&Materials #Retail(R)evolution #Safety

DOCOL[®]
HIGH STRENGTH STEEL

He couldn't care less
about bumpers.

But we care
about him.



When you're in the business of protecting lives, you need a team of the best experts. A team that is ready to solve any problem and ready to take the next step. A team that actually cares.

For over 30 years the global team at SSAB has supplied Docol branded Advanced High Strength Steel, which makes products lighter, stronger and more sustainable – so that every single car safety component can be optimized and more lives can be saved.

It's not about steel. It's about life.

www.docol.com

SSAB

Welcome

Welcome to *Automotive Megatrends Magazine* - the only global publication dedicated to the business models, technologies and trends which are shaping the automotive industry of tomorrow.

Core focus areas



Readership

Every quarter, *Automotive Megatrends Magazine* is sent to 20,000+ opted-in automotive industry stakeholders:

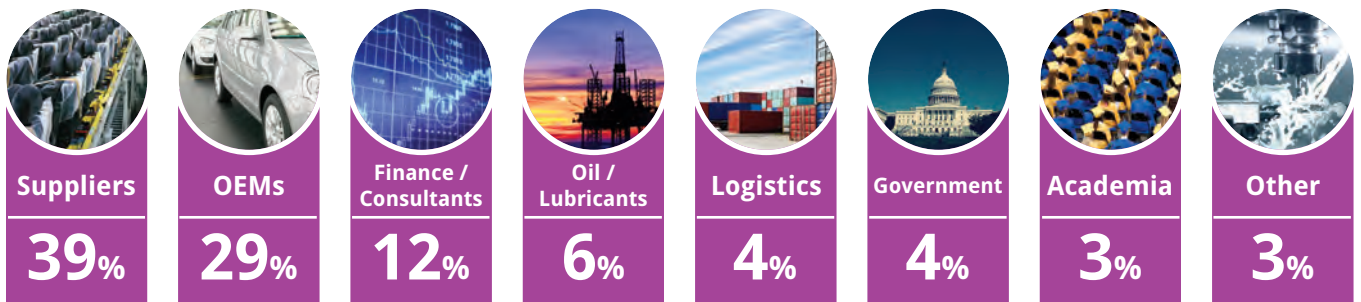

The publication is downloaded in more than 150 countries worldwide:



Automotive Megatrends Magazine
ISSN: 2053 776X

Publisher:

Automotive Megatrends Ltd
1-3 Washington Buildings
Stanwell Road, Penarth
CF64 2AD, UK

www.automotiveworld.com
T: +44 (0) 2920 707 021
hello@automotiveworld.com

Registered number: 08000516
VAT number: GB 171 5423 23

Editor:

Martin Kahl

Business Editor:

Megan Lampinen

Manufacturing & Materials

David Isaiah

Electronics & Safety

Rachel Boagey

Suppliers

Freddie Holmes

Powertrain & eMobility

Michael Nash

Production & Design:

Michael Franklin & Anmol Mothy

Chief Executive:

Gareth Davies

Contents

> Powertrain Innovation

> About this issue



Welcome to *Automotive Megatrends* magazine: the powertrain innovation issue

Soon, you'll be reading *Megatrends* magazine while sitting in a lightweight, electrically-powered, driverless car developed by a tech giant.

Mainstream media might have you believe your next car will match that description: you're never more than a swipe or a click away from an article about Silicon Valley leaving Detroit stranded by the road-side.

So, are we there yet? Nearly – in big picture terms, at least. But there's still considerable work to do: legislation is forcing technology when it comes to emissions, but advances in autonomous car technology suggest legislation is the barrier to progress. Add to that the growing consumer desire for personal transportation that offers the same experience as consumer tech, and there's sufficient demand.

How, then, do we get to that point in the future? This is *Megatrends* magazine. You've come to the right place to find out.

Enjoy the magazine and join the debate:



Martin Kahl, Editor



9 - Asia key for CVT growth

Punch Powertrain tells *Megatrends* about the growth of CVT in Asia

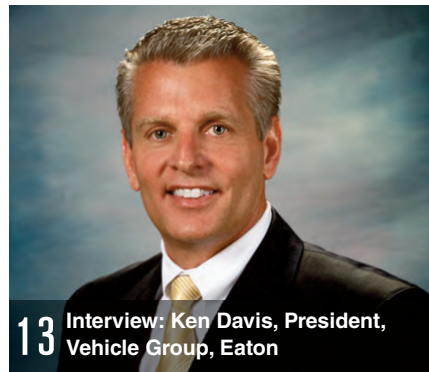

13 Interview: Ken Davis, President, Vehicle Group, Eaton



16 Interview: Dean Tomazic, Executive VP and CTO, FEV North America



19 Powertrain in focus: what's hot on the road to 2020



22 Fuel from plastic waste crucial for developing countries, says Cynar



25 AMT can boost MPG, says Kongsberg Automotive



28 Paving the way for a cleaner, greener solution - meet The Proving Factory

> Connected Vehicles



31 - Get the ecosystem right and connectivity can go global, says Infosys

Megan Lampinen talks to Sanjay Jalona about making connected car technology possible for all markets

43 - Tech development is disrupting traditional auto industry relationships

The automotive industry's switch from HTML5 to Qt is good news for ICS, as the company's COO, Mark Hatch, tells Megan Lampinen

47 - Smart maps show the way for the connected car

TomTom's Charles Cautley discusses the importance of intelligent mapping for the future of the connected car

50 - Over-the-air updates, of a different kind

Martin Kahl meets John MacLeod, Founder and Chief Executive of Rivet Radio

52 - When it comes to the connected car, it's all about "enablement"

Rachel Boagey talks to Marques McCammon, Senior Director, Automotive Product Management at Wind River

54 - Enabling choice, the GENIVI way

Megatrends talks to the GENIVI Alliance about its Android Auto interface and the news of Daimler's decision to become a member. By Martin Kahl



34 How, not why is the question now shaping connectivity development



37 Navigating towards a safe connected car



39 How to tackle the car hackers

> Freight Efficiency



56 - Bigger trailers for greater efficiency

What role can trailer design play in improving truck efficiency? Dick Giromini, President and Chief Executive of Wabash National, explains



58 Fleet managers - lap up the fuel-good feeling!



60 Interview: Jim Arthurs, Executive Vice President of Heavy-Duty Systems, Westport

> eMobility



63 - PHEVs - “a major step towards zero-emissions driving”

Michael Nash looks at some of the key PHEV launches at 2015’s CES and NAIAS



66 Range anxiety: information delivery is key



69 Squeezing pennies from the BEV segment

> Manufacturing & Materials



74 - ArcelorMittal believes it can ‘steel’ a lead over new powertrain developments

The world’s largest steel manufacturer says it can cut sufficient weight using steel to help OEMs close the powertrain gap and meet future emissions targets

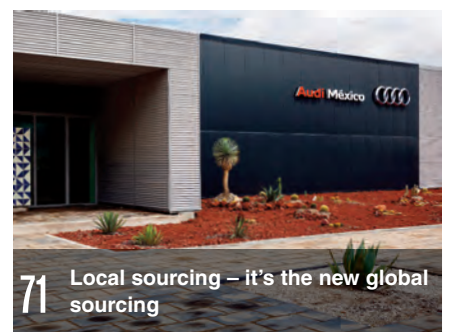

71 Local sourcing – it’s the new global sourcing



79 Under the hood, says DSM, there’s a great future in plastics

> Retail (R)evolution

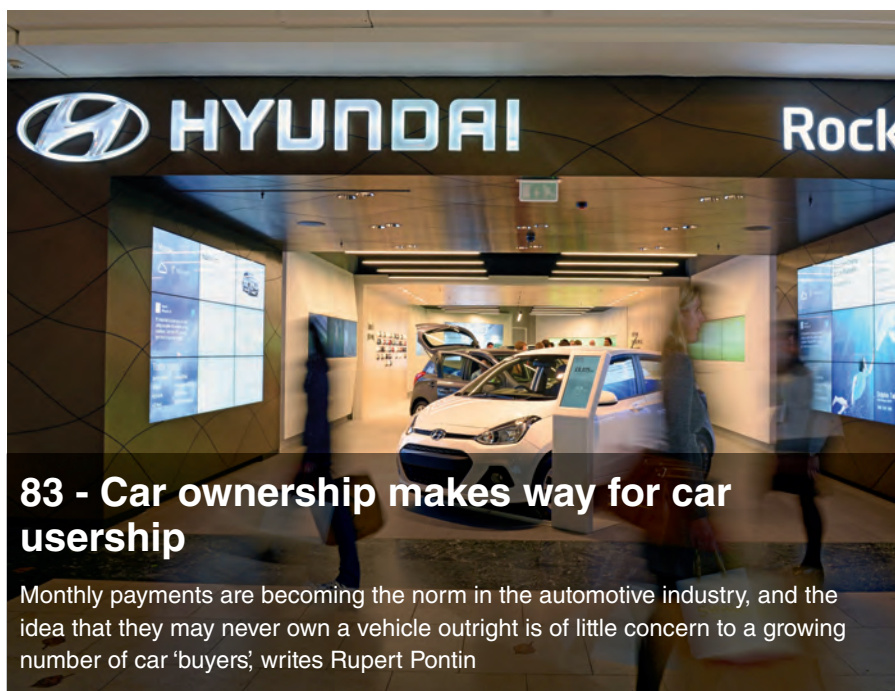

> Safety





PUNCH Powertrain N.V. is an independent Tier1 developer and manufacturer of continuously variable transmissions (CVT), electrical and hybrid powertrains for passenger cars.

In developing the new generation CVT and hybrid powertrains optimal performance, minimal fuel consumption, low emissions and driving pleasure are key topics.

Apart from different gearbox technologies, Punch Powertrain N.V. is leading in the fields of Switched Reluctance Motors (SR Motors) and flywheels.

With its SR motors, Punch Powertrain N.V. holds a key technology that is both cost effective as eco-friendly, due to the absence of rare earth materials.

Extensive experience with this technology makes Punch Powertrain N.V. the only partner that can provide all the benefits and none of the drawbacks previously associated with SR motors. SR motor technology is applied in Punch Powertrain's hybrid and electric powertrain solutions.

Punch Powertrain NV also offers solutions when the battery costs are an obstacle for hybridization. Flywheel technology allows Punch to offer cost effective hybrid solutions, that are easy to integrate.

More info about us on www.punchpowertrain.com

Punch Powertrain nv

IZ Schurhovenveld 4 125

3800 SINT-TRUIDEN, Belgium

Phone: +32 11 679 111

Fax: +32 11 674 808

E-mail: info@punchpowertrain.com

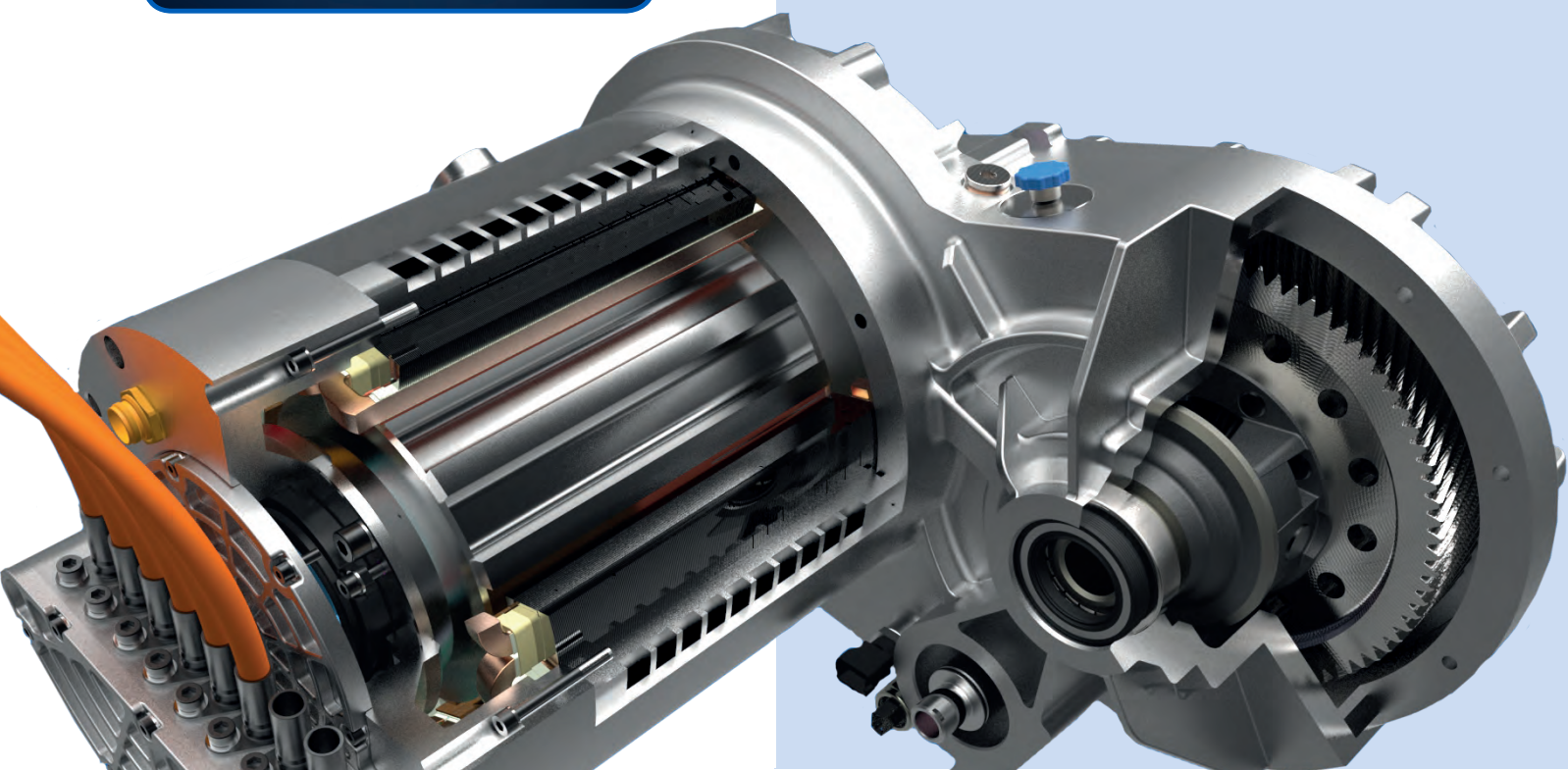

Asia key for CVT growth

Punch Powertrain tells Megatrends about the growth of CVT in Asia

By **Michael Nash**

According to industry experts, factors like high costs and lack of market awareness have caused the continuously variable transmission (CVT) market to suffer restrained growth. However, future emissions targets and the demand for an enhanced driving experience are generating growth in the segment.

Building on tradition

Former DAF subsidiary, Punch Powertrain, is a producer of CVTs. In the late 1980s, the company started to produce metal v-belt CVTs, and has continued with this development ever since.

Having developed a strategy to become a multi-customer organisation, Gert-Jan Vogelaar, Strategic Marketing Director at Punch Powertrain, says the next step is to become a multi-product company. "Over the coming two to three years, we will introduce a number of new developments. We will look to spread out globally. It is certainly an exciting time ahead of us."

Developing more components

Anticipating imminent growth, the number one priority for Punch Powertrain is to expand its product portfolio in order to access new markets. Consequently, the company is expanding out of its CVT roots, and has been making considerable efforts in R&D to develop various innovative components, such as its HT1 Hybrid Electric Powertrain and HT2 Flywheel Hybrid Powertrain.

The HT1 Hybrid Electric Powertrain, explains Vogelaar, was developed primarily with the Chinese market in mind. It has a switched reluctance (SR) electric motor which is connected to the output of the variator, minimising the impact of parasitic losses within the transmission. The HT1 aims to improve the fuel economy of the vehicle by around 35%.

The HT2 Flywheel Hybrid Powertrain targets emerging markets, and is ideal for countries like India, says Vogelaar. "You can keep the costs low, but you don't jeopardise the benefits in fuel efficiency." Although it achieves roughly half of the fuel savings compared to the HT1 Hybrid Electric Powertrain, the HT2 is far cheaper, not only on the transmission level, but even more so on system level as no batteries are required. Furthermore, the company is also working on its 'EV powertrain', which will utilise the same SR electric motor technology found in the HT1.

Along with these various powertrain developments, Punch Powertrain is producing a separate transmission that can be utilised across various types of hybrid and electric powertrains. Dubbed the VT5, the new transmission will be added to the growing CVT family that Punch Powertrain designs and manufactures.

Importance of Asia

Although Vogelaar details Punch Powertrain's strategy to grow in various markets, he suggests that Asia will remain a key market for the company, particularly for its existing CVT business. In fact, "90% of our customers come from China, and 70% of all automatic transmissions in the A/B segment will be sold in Asia by 2020," he says.

Apart from Asia, the US is also showing a renewed interest in CVT. "Four car models in

the top five US bestsellers are equipped with CVT,” explains Vogelaar. What is more, GM has recently announced it will produce a CVT. “In the C/D segment, about 70% of the automatics will be sold in the Chinese and US market combined. There will be a shift towards producing components that meet the demands of these markets, and the price of these technologies will fall,” he observes.

Originally, the perception of the high cost of CVTs has been detrimental to their uptake. However extensive cost reduction programs have enabled Punch Powertrain to succeed in the Chinese market. “We are now offering a very competitive package to the

Chinese OEMs,” claims Vogelaar. He also notes cost as a potential obstacle for the company’s new products. When considering its new hybrid and electric powertrains, the influence of incentives offered by Asian governments could be crucial to the success of the new technologies.

“We do have a huge interest from China for our hybrid and electric drive products,” he continues. “What we have also seen is that customers who are interested in these products show an interest in our CVTs as well, so it’s also helping us to sell more conventional transmissions. All our products are following the trend of improving fuel economy, and are very relevant in today’s market.”

Of particular importance, and a growing trend that Punch Powertrain expects to continue, is the adoption of 48 Volt (48V) applications. “I think 48V systems will start popping up quite a lot in China, as well as full hybrid systems,” suggests Vogelaar. “With things changing in terms of regulation both in Europe as well as in China, OEMs can hardly survive if they don’t offer hybrid 48 Volt and electric powertrain solutions,” he says.

In keeping with the theme of expansion, Punch Powertrain is developing a 48V system which it is targeting at the increasingly strict emissions standards that will be implemented by 2020.

Opportunity elsewhere

Vogelaar is confident that, by 2020, the Asian market will “dominate worldwide automatic transmissions sales in the A/B segment, and the combined Chinese and US market will dominate the C/D segment in terms of automatic transmissions sales.” Combining this with the trend of the reduced number of different components being offered by an OEM, Vogelaar expects that the requirements for the A-D segment cars and their transmissions will not be determined by Europe, but by Asia and the US. Consequently, “we are not going to make a specific transmission solely for Europe for these relatively low numbers,” he remarks.

Evidently, Punch Powertrain considers Asia an extremely important market for its growth and success. However, by investing its R&D efforts into products like the HT2 Flywheel Hybrid Powertrain, the company is showing its dedication and aspiration to become a supplier of innovative, clean powertrain technologies for a broader market.

What is more, “even though we do not have products other than our CVT in production at the moment, the fact that we are working on hybrids and EVs is a signal to our customers that we are not only a supplier for today but also for the future,” concludes Vogelaar.

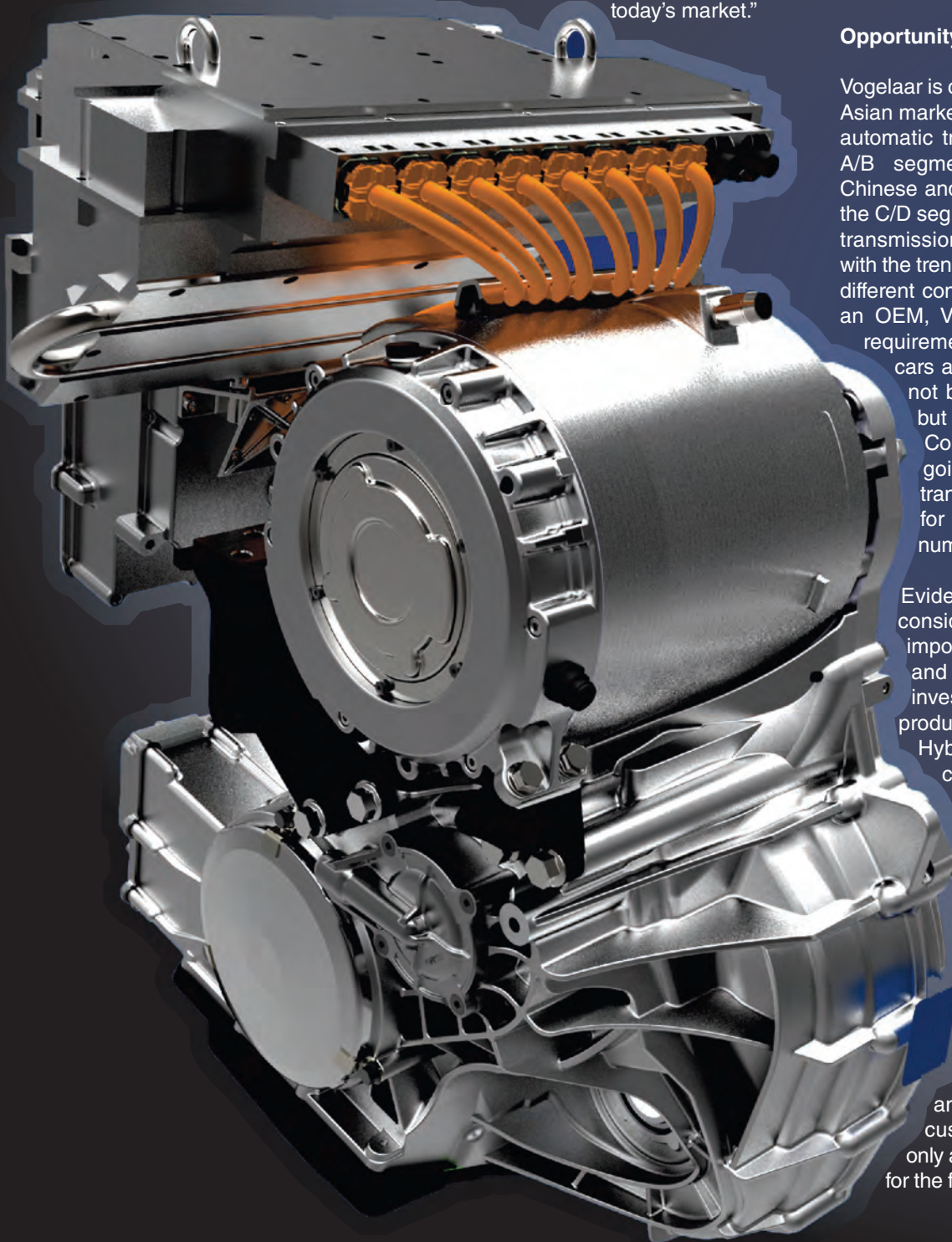

Hybrid transmission on Punch Powertrain's prototype assembly line at Sint-Truiden in Belgium

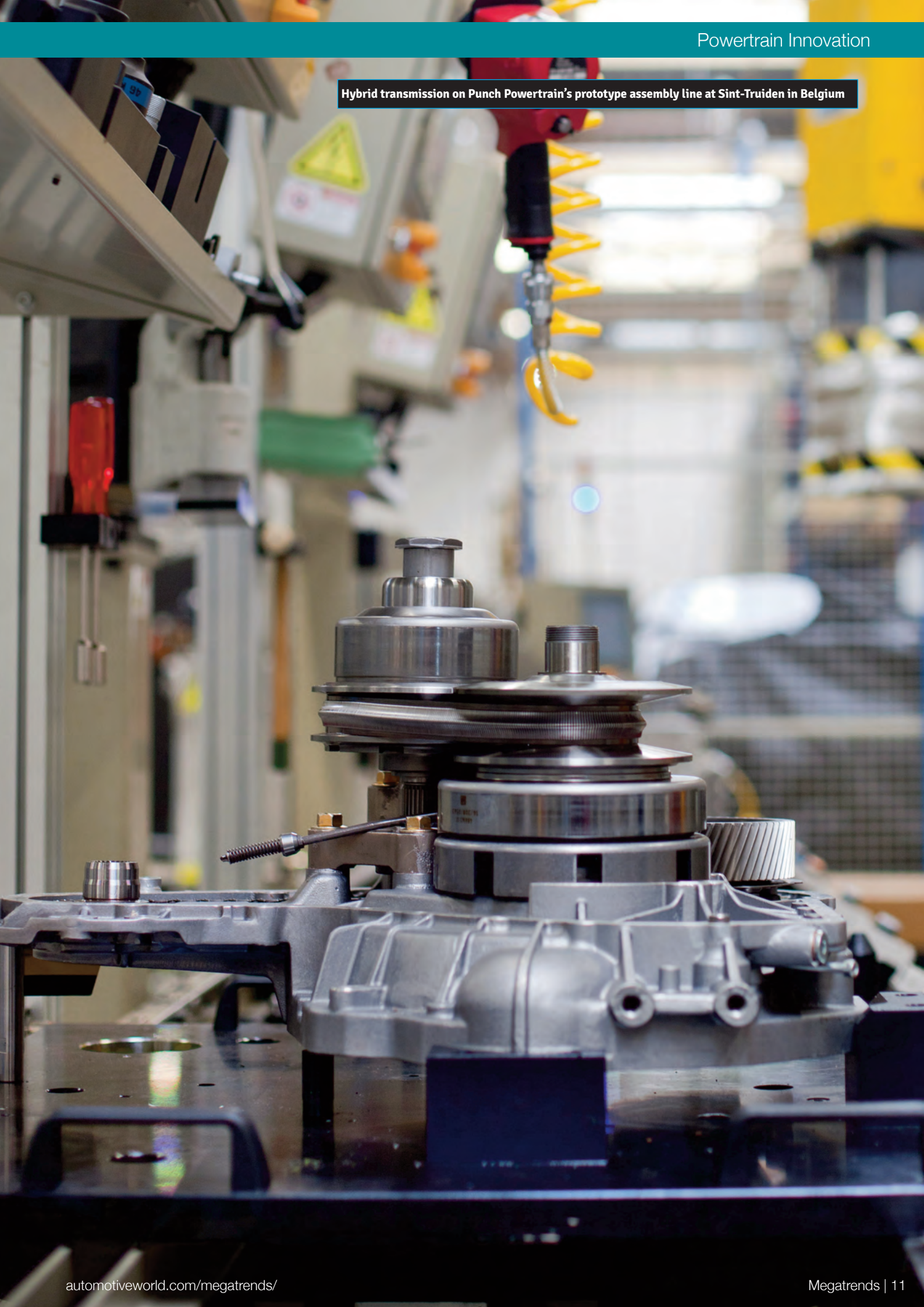

Green still means Go

...vehicle power made more
reliable, efficient, safe and
sustainable around the world

Sustainable Solutions

As a leading power management company, Eaton is uniquely positioned to answer the demand for cleaner, more fuel efficient vehicles. Our highly engineered supercharging and valvetrain technologies provide the fuel economy and thermal efficiencies required for higher power density engines. Innovative traction control and boosting technologies deliver compact packaging that improves performance and reduces component complexity. Eaton's engineered solutions are helping automakers around the world realize the promise of sustainable technologies.

www.Eaton.com

EATON

Powering Business Worldwide

Interview: Ken Davis, President, Vehicle Group, Eaton

Michael Nash talks to Eaton's Ken Davis about marrying performance and efficiency

Combining optimised performance and maximised efficiency is the Holy Grail for powertrain developers. This is the case for companies that operate within both the commercial vehicle (CV) and the passenger vehicle segments. A number of measures can be taken in order to get the right balance between performance and efficiency.

Power management

Many of the current trends seen in powertrain development, like boosting for instance, are a product of the aspiration towards more efficient vehicles without compromising on performance. In providing innovative powertrain products such as downsized and supercharged engines, the effective management of power is crucial.

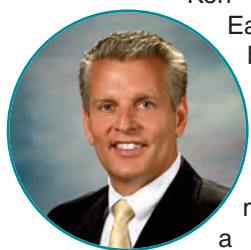

Ken Davis, President of Eaton's Vehicle Group, believes that the company has considerable competence and strength in power management. "We run a business of approximately \$4bn that covers all of the vehicle products within Eaton's Vehicle Group portfolio – everything from passenger vehicles all the way up to heavy-duty CVs. Our technology is really focused on helping our customers better manage power effectively, efficiently and safely.

"The power management area is also where a lot of our investment and

future capital is heading," he continues. With a significant amount of Eaton's future investment inevitably targeted at power management, Davis expects trends such as downsizing and boosting to become an ever increasing part of the company's work. "There is nothing startling – the same trends are governing our work," he says. Yet, there are two specific subcategories which will be of particular importance to the company in the near future: engine air management and drivetrain development.

Engine air management

Within the power management area, there are two smaller areas that Davis describes as flourishing for Eaton. These are "not the only areas, but are definitely two of significant focus for Eaton and the Vehicle Group."

The first is engine air management. "We are a leading supplier of engine valves to the global OEM and CV industry," he says. "At the moment, we are furthering our competence in this area by investing heavily in a lot of the new technologies for the enhancement of engine valves and valve trains," he adds.

Essentially, valve trains are an enabling technology for the downsizing and boosting trends, he tells *Megatrends*: "Engines and vehicles are being modified to produce more power and higher output at smaller displacement, with better fuel economy. That means engines tend to run hotter, which has a huge impact on the valves and the valve train system."

A relatively new addition to Eaton's range of powertrain valve solutions is



"We will offer a whole host of technologies and innovative ways to ensure our customers receive what they expect and deserve" - Ken Davis, Eaton

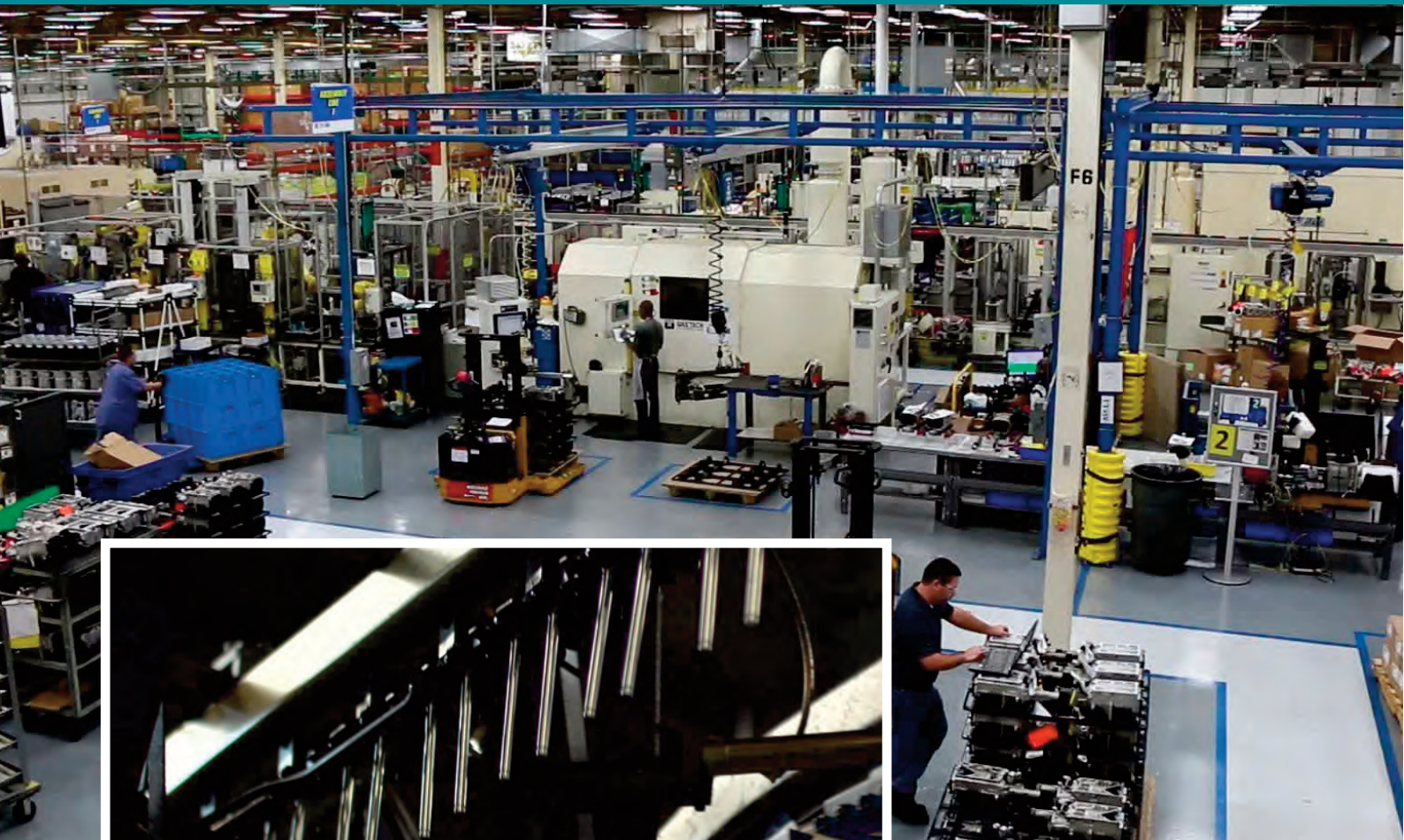

its advanced engine braking technology for heavy-duty CVs, which changes the valve lift between driving mode and braking mode according to customer requirements. In short, it is yet another technology that Eaton has produced in order to increase total cost of ownership, enhancing the efficiency of the powertrain and making engine air management more efficient.

Drivetrain development

The second area of focus for Eaton, and one in which the company is current investing considerable time and development, is drivetrain development.

“We also try not to lose sight of the performance side, because increasingly customers around the globe want better performance – that’s where our drivetrain products that we are developing can add some value.” Davis suggests that Eaton’s drivetrain business will also see significant expansion, with the further development of products in order to optimise the performance of vehicles.

“Whether it’s the torque products that we sell to the market, or transmissions and clutches on the heavy-duty CV side, we have a firm competence and understanding of the area,” he says.

Essentially, both areas are linked by a marriage between performance and efficiency. They are encompassed by what Davis describes as “intelligent power management – how to take the energy from the engine and deliver it to the wheels efficiently and without the loss of performance.”

Bringing in the big guns

Many industry experts believe the engine boosting trend will continue. Davis concurs, suggesting that the industry “will witness many larger and maybe heavier vehicles with smaller displacement engines, looking for the right level of power management to move the vehicle efficiently and effectively.”

In order to achieve this goal, Davis emphasises the importance of

developing a portfolio of valve train technologies, including variable valve lift and cylinder deactivation. “If we can help our customers make the combustion event more efficient through valve train products and air boosting products like superchargers, then we can add value in an important part of the vehicle.”

Eaton believes that its expansive range of valve train technologies will perform well in the near future, as the company looks to implement these new technologies into existing products, as these technologies can have a huge impact on improving the fuel efficiency and reducing vehicle emissions, says Eaton’s Vehicle Group President.

Essentially, Davis believes the future of Eaton’s Vehicle Group lies in succeeding in delivering a combination of optimising performance and economy. “It boils down to what all OEMs are looking for – improved fuel efficiency, emissions reductions and enhanced performance,” he says. “We think we can add value to our customers by making the vehicle more efficient and making power delivered to the ground more efficient. We will offer a whole host of technologies and innovative ways to ensure our customers receive what they expect and deserve.”



TURNING
INNOVATIVE
IDEAS INTO
REALITY

FEV is your innovation engine.

A partner you can trust, helping you evolve, perfect and accelerate new ideas. Speeding new technologies from simulation to design to application to market. From conventional powertrains to advanced hybrid-electric vehicles and connected vehicles, we develop custom solutions for our clients. We engineer innovation.

Together, we're redefining what's "possible" every day.

>3200
INNOVATORS

>150
TEST CELLS

>30
LOCATIONS

1
PASSION

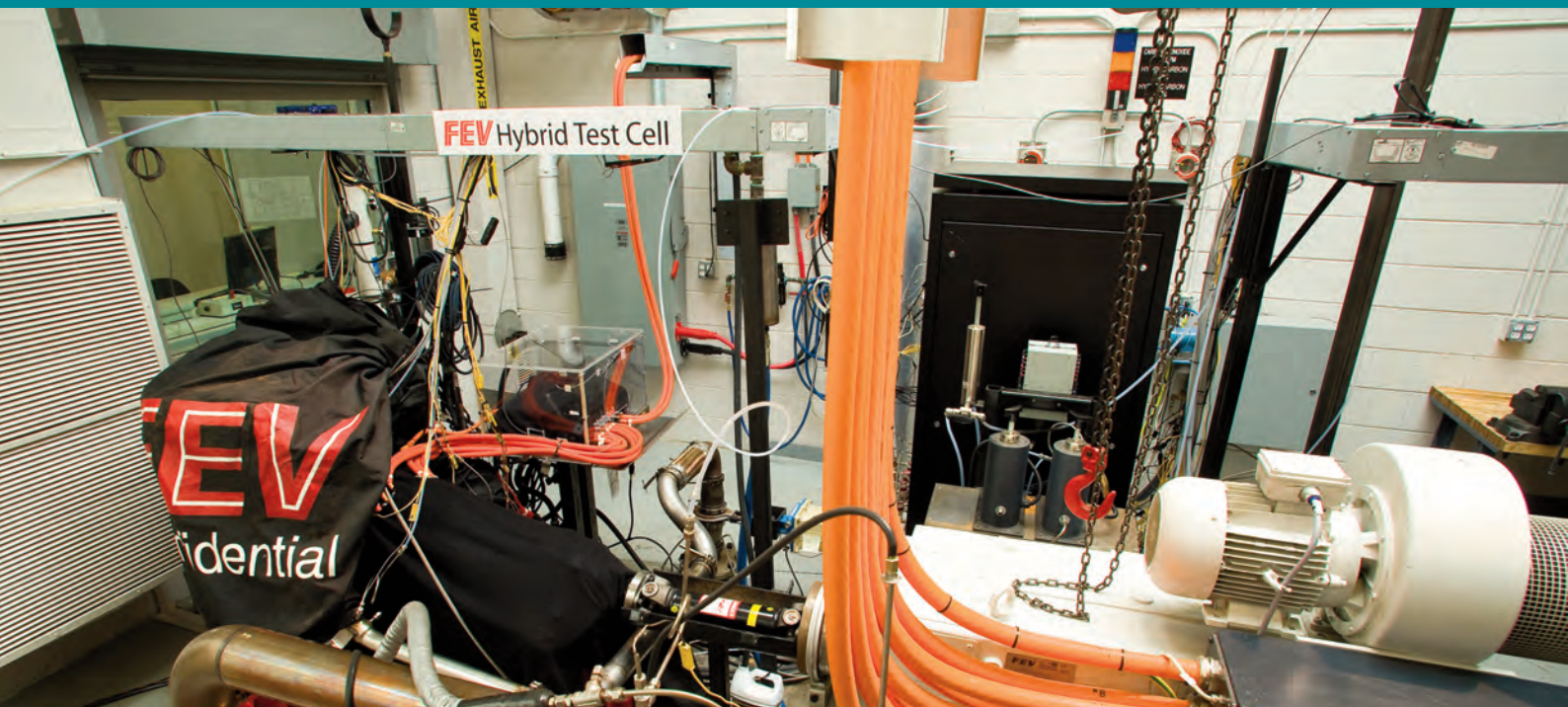

Interview: Dean Tomazic, Executive VP and CTO, FEV North America

*The importance of commonality and localisation form the backbone of this exclusive Megatrends interview by **Michael Nash***

Locality is essential, and it's what lies behind the positive growth being experienced by FEV across a number of markets, as Dean Tomazic, Executive Vice President and Chief Technology Officer at FEV North America, explained to *Megatrends*.

Tomazic is responsible for the company's activities in the North American market, overseeing powertrain developments. He supervises the work on various kinds of internal combustion engines (ICEs), from small passenger vehicle engines to large bore locomotive and marine engines. Beyond this, Tomazic is also in charge of the development of individual driveline components, such as transmissions and drivelines.

What are the current megatrends affecting your work at FEV?

Very high on the list are fuel economy and CO2 emissions, both of which are legislated here in the US. There is a

wide variety of different technologies that are being pursued in order to meet and address these requirements, ranging from downsizing and down-speeding to the light-weighting of vehicles. Considerable work has also been done on the transmission side in recent years. We have gone from five-speed manuals and automatics to now looking at ten-speed transmissions. We are also developing electrified transmissions for hybrid applications.

A big contributor is the variable compression ratio mechanism (VCR). We have developed two different systems – a continuously variable compression ratio mechanism, and a two-step. The two-step is essentially a simplified version – it is both easier and cheaper to incorporate, so we are seeing a lot of interest among our customers and several programs are on-going because of the high potential of such a technology to meet fuel economy and CO2 targets.



Fuel economy and CO2 emissions are two key megatrends shaping FEV's powertrain development work, says Dean Tomazic

What are the challenges posed by emissions standards and targets?

The US is the leader in terms of emissions, with the toughest standards worldwide. Clearly, a fleet average of SULEV 30 is a very stringent emissions level. But we already had SULEV applications in the marketplace

many years ago, so we don't believe that the future requirements are a major concern. However, this is an average for the entire fleet, which poses another challenge altogether, as we must look at a variety of different applications. It's one thing to do it with the smaller passenger cars, but larger trucks are another story. These are the challenges we are considering, and we need to meet them as cost effectively as possible.

How can OEMs and engine developers hope to meet future emissions standards whilst keeping costs low?

When we look at the design perspective for engines, we see the development of an increasing number of engine families as OEMs worldwide attempting to consolidate their engine platforms. This means that, within an engine family, the same combustion system and arrangement will be used, whether it's a three-cylinder inline engine or a six-cylinder inline engine. To save costs, commonality is king – it is crucial to include part commonality as much as possible within an engine family. This is something that we see everywhere. Even if the engine that we develop with our customers is not necessarily part of an engine family, we are still required to approach it from the perspective that we should have as many common components as possible to further reduce costs.

Can OEMs use this theme of commonality to make hybrid powertrains cheaper?

When you look at the hybrid powertrain versus the conventional powertrain, there is a requirement for the engine to change. You wouldn't necessarily use the same engine in a hybrid powertrain that you would put into the same conventionally powered vehicle.

Instead of using a six-cylinder engine that would be placed in a conventional vehicle, you utilise a much smaller engine in the hybrid system. No matter where you would incorporate these engines, if they are part of an engine family they will cost less. On an absolute basis, the engine that would be integrated in that application wouldn't cost more in a different vehicle because it's the same engine. Of course, the smaller engine is generally cheaper than the six-cylinder base version, but the cost savings will be partially, if not fully, offset by the



additional components that are part of a hybrid system.

Commonality could help reduce the cost of hybrid vehicles, but whether it makes it more attractive to an extent that would push the consumer more towards a hybrid is less clear.

What are the main factors driving FEV's global growth?

We have several technical centres worldwide that we have established over the years, and this is really necessary in order to support our customers locally. We do not believe it is possible to have one central company supporting our customers worldwide. Locality is essential, and you have to have all the capabilities to support your customer from a product engineering perspective.

We have structured FEV to establish business units that individually address the different market areas, including electronics and electrification. We acquired a company called DGE that deals primarily with infotainment, telematics, car-to-X communication and autonomous driving. Those are all things that we are intensively working on, and that are crucially important to FEV going forward. Again, they are best done locally, not centrally.

Localisation is a growing industry trend - can you please elaborate on that point?

Localisation of manufacturing is gaining traction, where the world's largest OEMs build engines within a country that are intended for a local

market. Instead of having centralised plants and transporting engines from, for example, Europe to various other markets, OEMs are manufacturing them at the same quality level for a much lower price in local markets.

This is an area where we provide significant support to our customers from a value engineering perspective. Our production engineering group provides services to our clients, to investigate how much it would cost to manufacture components in different areas of the world. So we support our customers in making these kinds of decisions.

Does the localisation of plants for companies make the commonality issue harder to address?

No, because at the end of the day, all of these engines need to fit into certain vehicle platforms and, hence, follow the same design and manufacturing requirements. It requires strategic long term planning, and isn't something that can be done overnight. But once this is a fit, you essentially build the same engine that you would in Europe, for example, as in the US, or Mexico, or wherever it would be. The engine still fits into the same vehicle platform.

There are different requirements in different markets, so it must be considered from the start that everything will fit into the vehicle. But if that is being done, then, from a commonality perspective, there is no disadvantage in manufacturing components, engines, or entire powertrains somewhere else, as long as the quality is equivalent.

Coming
soon!

**We've been
set a target of
54.5mpg by
2025.**

Check out our free guide to
the companies making that happen.

<http://guidetopowertraininnovation.com>

Powertrain in focus: what's hot on the road to 2020?

Automotive industry experts from Frost & Sullivan analyse trends in powertrain technology.

By **Sujeesh Kurup**, Consultant and **Anjan Hemanth Kumar**, Program Manager

As the automotive world heads towards the next generation of stringent emissions and fuel economy targets, all aspects of the internal combustion engine (ICE) are subject to close scrutiny.

Inherently, ICEs are very inefficient, with efficiency varying between 18 - 40%. This efficiency is a function of friction losses, pumping losses and wasted heat. Currently, automotive OEMs globally are hard at work trying to attack these issues with various solutions to achieve incremental gains.

Engine downsizing

The leading trend is to generate more power from less space, also known as downsizing; this is leading to a

reduction in the number of cylinders and a decrease in displacement while maintaining the power output that consumers demand. A secondary reaction to downsizing is the move from a naturally aspirated fleet to a turbocharged fleet. To gain efficiencies and power output, better control systems are a necessity; hence, valve train and fuel delivery systems are heavily controlled and optimised to meet emissions and fuel economy targets.

Let's consider how powertrain types varied by region. In 2014, gasoline engines accounted for around 87% of the Chinese passenger vehicle powertrain mix, with diesel engines accounting for about 10 to 12.5%. In 2014, 71% of ICEs sold in China had a displacement below 1.6 litres, and 20%

of engines sold were between 1.6 - 2.0 litres. In South Korea, 45% of engines sold had a displacement of below 1.4 litres, and 37% of engines sold were between 1.5 - 1.9 litres. In total, 82% of South Korean engines had a displacement below 1.9 litres. In India, about 62% of diesel engines are between 1.0 - 1.6 litres, while that same engine size range accounts for about 48% of gasoline engines. Up to 36% of gasoline engines sold in India are expected to be below 1.0 litre by 2017. The trend in the Asian market is that majority of passenger vehicle engines will be below 1.5 litre displacement after 2020.

Downsizing will provide consumers with some of the most efficient ICEs the world has ever seen in the mass market. This can also be seen as a trend transitioning ICEs from a primary propulsion source to a secondary power source.

Downsized engines to be turbocharged

There is a correlation between the forecast for engine downsizing and the global sales forecast for turbochargers; as engine displacement falls, turbocharger sales increase to satisfy the customers' power thirst. This is particularly clear in the global growth forecast for 1.0 - 2.0-litre displacement engines. Global Tier 1 suppliers like Honeywell, Continental, Bosch Mahle Turbo Systems and BorgWarner are aware of this increasing trend and are in the marketplace ready for the OEMs.

Figure 1 - Powertrain market: evolution of average engine displacement, 2008 - 2020

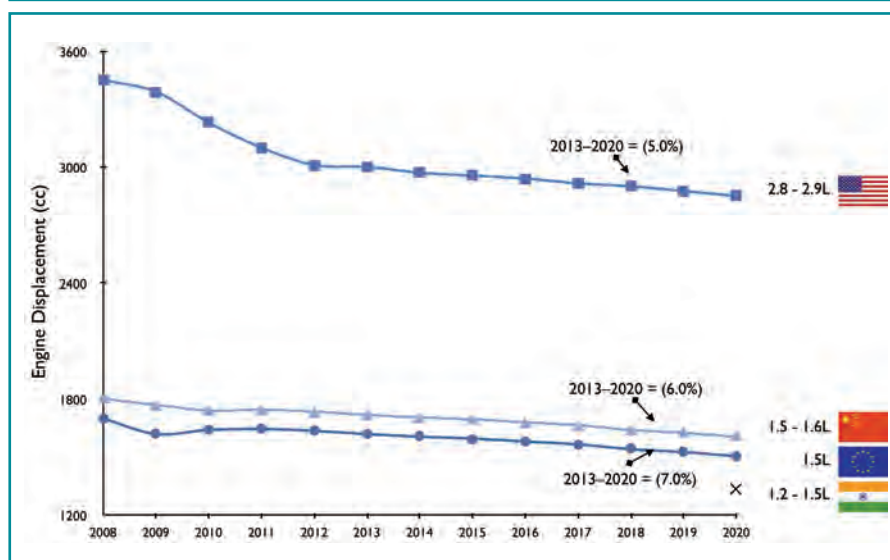
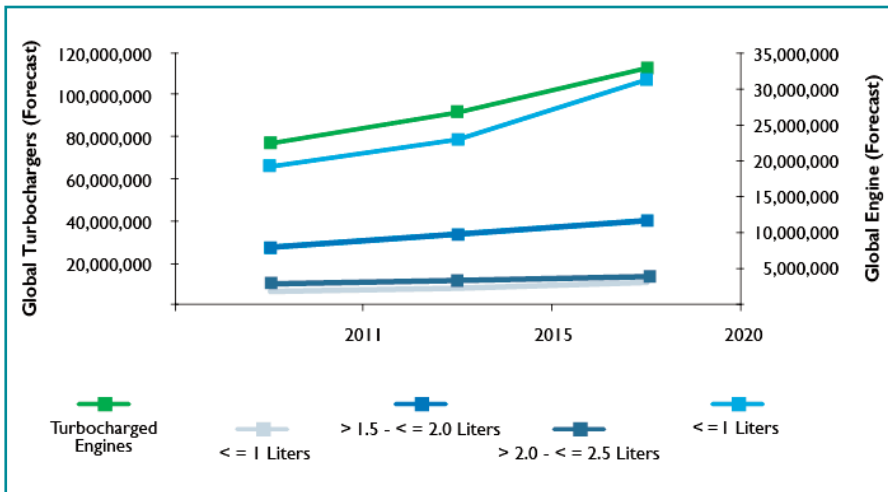

Figure 2 – Turbochargers forecast vs. downsized engine forecast



Controlling fuel and valve train

Better valve train controls with variable valve timing (VVT) for intake and exhaust valves, variable valve lift (VVL), and direct injection technologies help reduce the wasted heat and pumping losses. Gasoline and diesel engines both have advanced direct injection technologies to optimise combustion efficiency.

The control and durability of the direct injection system provides engineers the dynamic ability to optimise ICEs to meet customers' needs. There is unquestionably a trend towards ICEs with direct injection regardless of fuel type.

Dual Overhead Cam (DOHC) is the dominant valve train technology today and is expected to continue its domination through 2020. DOHC provides engineers the access to control the intake and exhaust valves far better than SOHC or OHV valve train systems. The growth of DOHC is thus logical and should be expected.

The leading growth in powertrain innovations are ICE downsizing, turbocharging, direct injection and valve train controls. These innovations, when combined, provide the automotive OEMs with a unique set of synergies to reach emission targets, fuel efficiency gains and customer satisfaction.

Powertrain lightweighting

Due to the importance of downsizing, direct injection and other technologies, it is imperative to highlight another key area where OEMs are expanding their limits to gain those extra few kilometres per litre of fuel: weight reduction. From

an emissions perspective, it is estimated that every 50kg of weight reduced from an average 1,500kg vehicle cuts CO2 emissions by 4-5 grams. Frost & Sullivan studies indicate that a vehicle with an average weight of 1,500kg has the potential to lose up to 35% of its weight by 2020, consequently causing powertrains to be about 8% lighter than existing offerings.

The key areas of the powertrain in which OEMs will focus their weight reduction efforts will be engine, transmission, exhaust, fuel system, casing, batteries and motors. Studies reveal that it is possible to reduce about 100kg in the medium term, enabling savings of about 8g CO2. The key drift in material technology is likely to happen with heavier engine components like cradles, engine blocks, cylinder heads and gears. While engines will constitute of an increasing level of advanced high strength steel (AHSS), aluminium and magnesium, some steel-based transmission parts are likely to shift towards the use of polyamides (PA); both cases offer weight reduction possibilities of up to 40% in the medium term.

The key to OEM lightweighting strategies is targeting the right application for the right segment. While larger segments have the price cushion to pass on compliance cost to owners, mid-sized cars will have moderate compliance costs that will impact purchasing decisions if passed on to buyers. Smaller segments have price sensitive buyers, but the relative compliance costs are also less impactful.

Innovations in noise, vibration and harshness

Engine innovations such as stop-start systems, hybrid and plug-in hybrid technology, cylinder deactivation and turbocharging technologies increase the NVH (noise, vibration and harshness) challenges on a vehicle, due to the variations in the layout and transfer path. Such challenges have led to innovations in engine mount and noise cancellation technologies.

Honda was one of the first OEMs to commercialise mass-market active control engine mounts in its cylinder-deactivated V6 engines. Led by the German OEMs, the vehicle manufacturers in Europe are adopting sophisticated active mounts on premium vehicles. Audi and Porsche have fitted unique and sophisticated electromagnetic oscillating coil and magneto-rheological engine mounts respectively on the Audi S8 and Porsche 911. These vehicles also come with active noise cancellation which counteracts unwanted noise through destructive interference, thus almost eliminating any airborne noise from the vehicle. The epitome of innovation is within the active exhaust system, where microphones are installed on the exhaust to absorb unwanted frequencies, and speakers produce characteristic sound. The speakers can be tuned to produce an authentic

Figure 3 – Fuel delivery system forecast

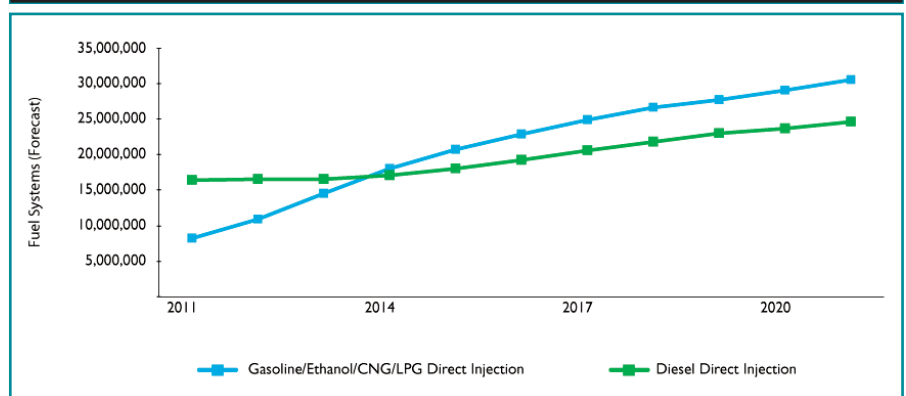

Figure 4 – Powertrain lightweighting potential, 2015

Component / System	Conventional weight (kg)	Lightweight option (kg)	Weight reduction potential
Transmission	90 - 100 (stepped automatic)	65 - 70 (low cost DCT)	25 - 35%
Cylinder block	43 - 45	32 - 33	29 - 30%
Valve train and fuel system	15 - 18	10 - 11	35 - 40%
Other engine components	25 - 28	20 - 23	13 - 18%

signature sound; the vehicle's engine sound can be changed according to the driver's mood or the vehicle's mode. A system developed by exhaust sound engineers from Eberspächer is currently being tested in Europe.

Beyond Euro 7 – exhaust gas heat recovery innovations

On average, two thirds of the fuel energy is wasted through the exhaust gases and the cooling liquid. In order to minimise fuel consumption and engine emissions, the conversion of exhaust heat energy shows great potential. Wasted heat can be utilised indirectly for power generation using a Rankine cycle, or directly for thermoelectric generation.

A thermoelectric generator (TEG) converts heat directly into electricity in

a simple and reliable way, known as the Seebeck Effect. Currently, various integration configurations are being evaluated and 200-1000W energy recoveries have been achieved. Cost and technology infancy are the major barriers for TEGs. OEMs such as BMW and Ford are leading development programs, with the former likely to be the first to commercialise this technology closer to 2020. Fuel economy gains of 3 - 7% are achievable through TEG systems.

An indirect method of exhaust heat recovery using the Rankine cycle is based on the steam generation in a secondary circuit using the exhaust gas thermal energy to produce additional power by means of a steam expander. A Rankine cycle engine makes only minimal impact on the engine pumping losses when

compared with turbo-compounding. Also, with respect to a TEG, a Rankine cycle engine provides higher efficiency of heat recovery. However, cost, weight and reliability are major challenges for Rankine cycle recovery systems, and are unlikely to be commercialised before 2020. Although BMW and Ford have demonstrated Rankine cycle engine concepts, Honda is one of the OEMs looking to pursue Rankine cycle technology for hybrid applications in production vehicles. Vehicle power output can be boosted by about 10 - 15% using Rankine cycle engines.

Alongside energy recuperation, exhaust heat recovery (EHR) systems are considered as one of the key energy recovery technologies preferred by OEMs as we head towards 2020.

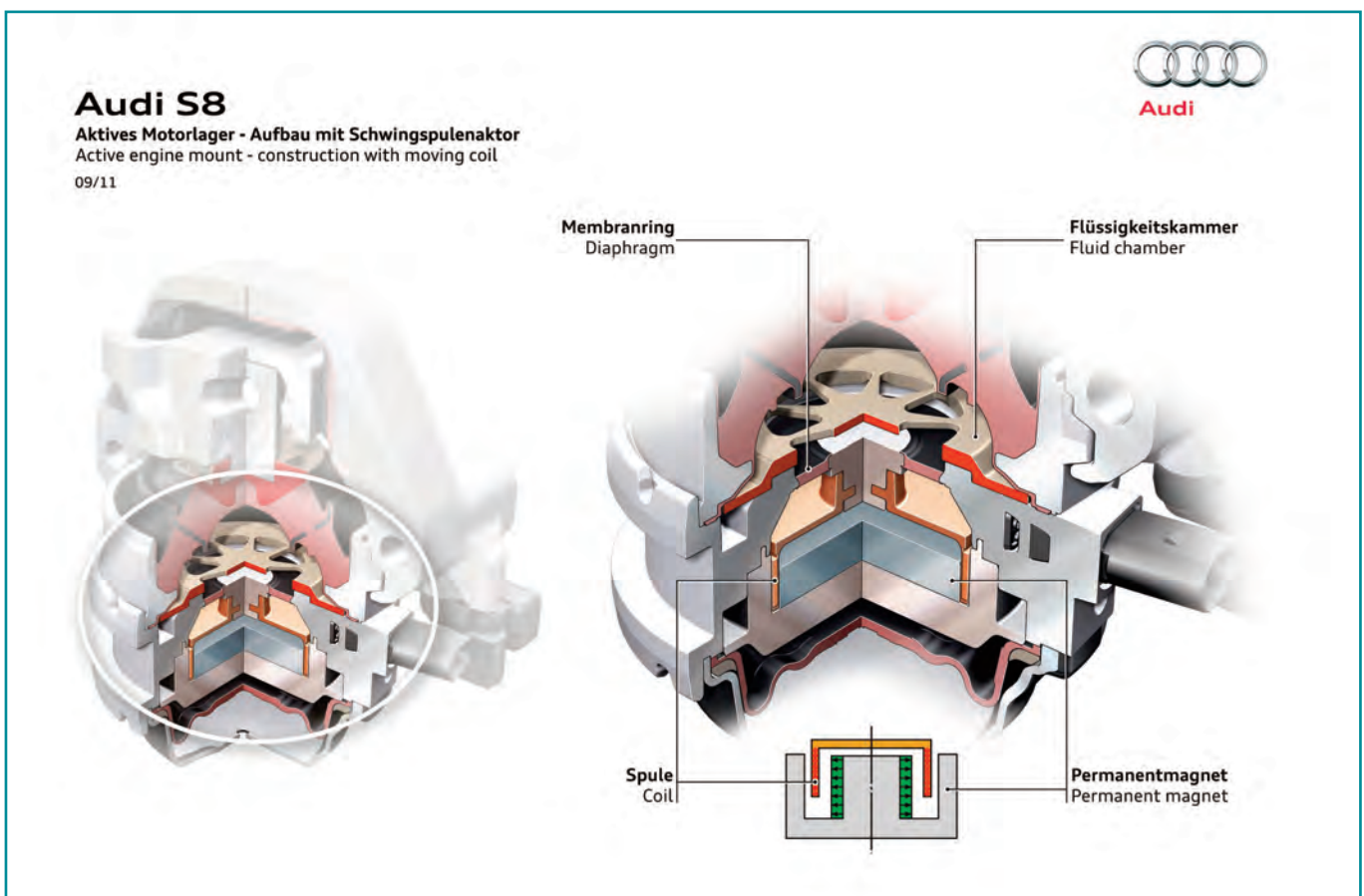



Fuel from plastic waste crucial for developing countries, says Cynar

*The process of obtaining fuel from waste plastic could be extremely beneficial for developing countries. By **Michael Nash***

According to the United Nations Environment Programme (UNEP), the world has been increasing its production of plastic materials by approximately 5% per annum for the past 20 years. Consequently, the amount of plastic waste being generated has grown significantly. This is particularly significant in developing countries, in which economic growth and changes in production patterns have caused waste plastics to be a major issue.

A serious threat

Cynar is a global supplier of sustainable and smart waste management systems, specialising in obtaining fuel from waste plastic in an environmentally clean manner. The

company is aiming to re-define “waste” – turning problematic materials into a source of prosperity.

Over the past five years, Cynar has seen growing demand across the world for plants that convert waste plastic into fuel. It expects part of this demand to come from developing countries. Michael Murray, Founder and Chief Executive of Cynar, says that developing countries and emerging markets within the automotive industry could benefit greatly from turning waste plastic into fuel. He describes the current state of waste plastic in many of the countries he has personally visited.

“Many emerging economies have increased their production of plastic in

the past few decades. With a lack of efficient end-of-life management, plastic is discarded and strewn all across the land. There are little or no waste collection regimes in place, or landfill regimes. Waste plastic also clogs up waterways and seas, and is generally posing serious threats to both the environment and human health.”

Totting up the benefits

Murray believes that by utilising this plastic waste, developing countries and emerging markets could benefit in a number of ways. First and foremost, there would be a “huge improvement in health and living conditions,” by both getting rid of dangerous waste plastic and improving the quality of air. Cynar claims that the diesel obtained through

its waste plastic programme is approximately 25% cleaner than conventional diesel in terms of tailpipe emissions, and could therefore have a substantial impact on the quality of air, particularly in megacities.

Another positive in using waste plastic, and one that Murray is extremely excited about, is the effect on local economies. "If we put a plant on the ground in a developing country, the poorer communities may benefit," he explains. "These guys have no income, and we will pay them at the gate. They can go out, collect and bring in waste plastic. They would receive a certain amount of cash per kilogramme. Furthermore, the local plant would produce fuel to go into their generator, giving them lighting and electricity, making a huge difference to their living conditions. It doesn't come much better than that for me," he added.

How it is done

Each plant would aim to collect around 20 tonnes of waste plastic, gathered locally every day. Murray explains that this amount of plastic allows the company to produce a substantial quantity of fuel without spending long hours and vast amounts of fuel by driving trucks over long distances to collect and transport plastic. "We can produce approximately 19,500 litres of fuel from 20 tonnes of plastic waste – that's enough to fill up around 500 small cars," states Murray.

Once collected, the plastics are heated in an oxygen-free chamber. When at temperature, vapour is created and collected for distillation. As the plastic is heated in a contained system, the vapours and emissions are minimised and controlled. The plant design utilises all gases and vapours produced and any by-products – such as carbon black – can be sold as a usable product.

Murray explains that turning plastic into fuel is a reverse process, as the plastic started out as oil originally. This, he claims, is the reason that Cynar's diesel is of high quality: "If you take a barrel of oil, where it starts life and it makes all sorts of products out there, the very best of that oil is used for plastics. And that's the reason why we reform it back into a liquid, because it starts life as the really good stuff out of that barrel, so there's no black magic in it at all. It's just started life really good and we are just turning it back into that and refining it."



The company is set to build a minimum of 20 plants between by the end of 2016, throughout Europe and Latin America. Murray knows that this is a tall order, but is confident that Cynar will deliver. The rapid growth is coming, in part, from the company's aspiration to penetrate the developing markets. However, making a difference in these countries will be a slow process. "It won't happen in this generation, but maybe two generations from now developing countries could benefit from a regular income generated by the plants, providing they are installed

now. At some point in the future, that community can start standing on its own two feet," explains Murray. "Whilst we have to be commercial, there are parts of the globe that this must reach. I'm nearly doing a Bob Geldof, and am talking to the likes of the UN, the European Union, the World Health Organisation and others, to discuss how to bring the plants to developing countries. It needs to be done," he added.

A version of this article first appeared on AutomotiveWorld.com

AW

Automotive World

Informing the decisions of automotive industry stakeholders since 1992.

<http://automotiveworld.com>



AMT can boost MPG, says Kongsberg Automotive

David Isaiah talks to Kongsberg Automotive's Bo Hansson about the role of transmission in the quest for improved fuel economy

With the US and Europe leading the clampdown on greenhouse gas emissions and pushing for standards that call for further vehicular emissions reductions and improved fuel efficiency, automotive OEMs and suppliers are being forced to innovate and develop technologies to conform to these stringent norms.

Many vehicle manufacturers are looking at vehicle weight reduction as a way to improve fuel efficiency. This works in two ways; firstly, a reduction in vehicle mass translates directly into better fuel mileage as there is less weight to propel. Secondly, a lighter vehicle allows for a smaller engine and thereby better fuel mileage.

One way of reducing a vehicle's weight is to replace conventional materials like steel with alternative lightweight materials such as aluminium, carbon

fibre, advanced high-strength steels, plastics, or a combination of these, resulting in a multi-material approach. Another way of improving fuel efficiency is to work on the vehicle's powertrains.

Powertrain advancements, too, can contribute significantly towards better fuel efficiency and reduced emissions. One such company involved in developments in driveline technology for passenger cars is Kongsberg Automotive. The company's passenger car driveline division develops components for manual, automatic and shift-by-wire systems, which it says puts it in a unique position with an overall view of the direction that driveline innovation is headed.

Overall, the market worldwide is more or less evenly matched between automatic and manual transmissions,

the supplier says, adding that fuel economy, comfort and price are among the main factors behind developments in automotive transmissions.

"You might think that automatics are taking over, but especially in South Asia and India, with the volume of cars there, they are normally manual due to price and cost for the product. So they are holding back the automatic transmission development, and growth," says Bo Hansson, the Norwegian company's Vice President of Research & Development – Driveline.

And talking about markets around the world, there is much emphasis on localisation these days, with countries trying to protect the local manufacturing segment by imposing tariffs and duties on imported components, making it expensive to import finished

components or parts. Kongsberg's approach is to set up production plants at its customer locations.

This has resulted in a global network of driveline system production plants, with facilities in India, China, Brazil, Europe and Mexico. The company believes a global presence is essential to be able to supply the OEMs' global platforms. This global presence has also helped the supplier avoid being hit hard by the slowdown in Europe.

"So far we have not seen much of a slowdown, to be honest. In terms of sales, we are pretty aligned with our plans," Hansson tells *Megatrends*.

Automated manual transmissions (AMT) are fast gaining interest in emerging markets, and AMT technology is widely regarded as the best technology for markets such as India, where automatic transmissions are not cost effective. AMT growth is aided by the fact that AMT and manual transmissions are fairly similar, with their use being defined by customer preferences.

One particular area that Kongsberg focuses on for AMTs is the shift mechanism. "In India we see growth that is not only driven by environmental reasons. The income level is lower, so fuel economy and price very much dictate the kind of car that people buy. And an AMT has better fuel economy performance than an automatic transmission," says Hansson.

Among its range of products, Kongsberg develops efficient actuation

solutions for AMT systems. While most of the current solutions are electro-hydraulic, the company believes that in the long run, the market will shift focus towards electro-mechanic solutions, and Kongsberg is focusing on this area accordingly.

But how much of a contribution can transmissions, specifically, make with regard to fuel efficiency and emissions reductions? Kongsberg's Hansson believes that transmissions can make a significant difference to fuel mileage, although quantifying this is a challenge.

AMT's contribution towards fuel efficiency depends on the efficiency of the software and the tuning of the transmission, he explains. At the same time, testing and drive cycle play a key role, with the European and US drive cycles producing different results.

"The best transmission [with regard to fuel efficiency] is generally an AMT because it is a manual and you control the shifts according to the driving cycle," says Hansson.

Fuel economy will be the defining factor behind future vehicle development, believes Hansson. Alongside that will be the expansion of electrification into all areas, something which requires suppliers like Kongsberg to be capable of delivering a portfolio of electronic solutions, including software and all types of human machine interfaces.

Another area that Kongsberg is currently working on is the relationship between shifting and safety. Here, the company

is working with an OEM and a university, to study the safety aspects of gear shifting. Essentially, this study strives to understand where a driver's eyes are focused while shifting, where their hands are placed and even how a driver reacts in a new car, for instance, a rental car.

"We're looking at all safety critical items, to define the best way of shifting gear in a controlled way. We see so many solutions on the market, and we see that other OEMs are also looking at different solutions," Kongsberg's Hansson tells us.

"It is about how you avoid unexpected direction changes, how to avoid unexpected acceleration, and how to avoid lack of expected acceleration. There are many critical issues between man and machine."

With vehicle manufacturers focusing on weight reduction, and with a variety of new materials like carbon fibre composites coming in, there is a need for suppliers like Kongsberg to also bring down the weight of their components.

"Everything that is downsizing and down-mass is an advantage in the competitive quotations we are into. The lighter the shifter, the better, and we are utilising our simulation team a lot. Even in the quotation phase, we have been able to show customers how we can meet their requirements even before we have the part," Hansson explains. "And we do that 100% in a simulation environment."





KONGBERG
AUTOMOTIVE

Kongsberg Automotive



Kongsberg Automotive provides world class products to the global vehicle industry. Our products enhance the driving experience, making it safer, more comfortable and sustainable.

Enhancing the driving experience

Our Business

With revenues of close to EUR 1.0 billion and approximately 10.000 employees in 20 countries, Kongsberg Automotive is truly a global supplier. The company is headquartered in Kongsberg, Norway and has 32 production facilities worldwide.

Our Products

The product portfolio includes seat comfort systems, driver and motion control systems, fluid assemblies, and industrial driver interface products developed for global vehicle manufacturers.

Our Business Areas

Kongsberg Automotive Group is organized into four business areas, Interior, Driveline, Fluid Transfer, Driver Control, each with a clear customer and product focus.



Paving the way for a cleaner, greener solution - meet The Proving Factory

Robert Last, Director of The Proving Factory, discusses the opportunities that the current political, economic and environmental landscapes offer low-carbon vehicle technology developers and OEMs

Drivers around the world are seeing a reduction in the price of fuel at the pump as the recent major decline in the crude oil price feeds through the supply chain. But while drivers are rejoicing, the electric vehicle industry is getting understandably nervous.

Ian Robertson, BMW board member, admitted in a recent interview with *CAR* magazine that electric cars such as the BMW i3 will become a harder sell if low fuel prices continue to erode the attractiveness of EV running costs. However, the good news for the EV market and all of those involved in the development of more environmentally friendly technologies is that this trend is unlikely to last. The currently low oil prices are not sustainable, and in the long term pump prices will continue to rise.

According to EU data, cars are responsible for 12% of EU CO2 emissions and there is little evidence of a wholesale move to alternative modes of transport. In fact, the UK's Society of Motor Manufacturers and Traders (SMMT) predicts that vehicle production in the EU will continue to increase in the foreseeable future. Current European legislation requires car manufacturers to achieve fleet average CO2 emissions of just 95g/km by 2021; however, that is likely to become even more stringent with proposed reductions to around 70g/km, potentially as early as 2025. For manufacturers, the pressure is on.

As well as EU regulations, fuel efficiency will be driven by a combination of economics, local authority requirements and consumer desire. One example is the Ultra-Low Emission Zone (ULEZ) proposed by London Mayor Boris Johnson. The public consultation on the initiative,

which has just closed, was driven by ambitions to reduce CO2 and air pollutant emissions from road transport and to stimulate the low-emission vehicle market, with suggested ideas including introducing a vehicle emissions charging scheme in central London, alongside proposals for buses and revised taxi and private hire licensing requirements. Air pollution is also an issue in a number of other cities and measures to reduce pollutant emissions to levels required by the European Ambient Air Quality Directive will place restrictions on vehicles entering a ULEZ or one of the Low Emissions Zones (LEZ) likely to appear in the not-too-distant future. Innovation will be the key ingredient that will enable OEMs to meet the challenges they face.

And while public attitudes towards electric vehicles in particular are very varied, sales of battery EVs and plug-ins grew markedly in 2014. Alternative powertrain technologies are welcome - and they're needed now.

While the problem has been identified, it's not clear cut and there is no one-size-fits-all solution; different technologies are required for different applications. An example is differing duty cycles: cars designed to be driven 100 miles (160km) at motorway speeds have different requirements to buses destined for start-stop operations in city centres. This is

what initiatives such as The Proving Factory have recognised. No one technology will win. There is no panacea; rather a whole host of technologies are needed, offering ample opportunity to technology developers to contribute to the solution.

The Proving Factory was launched in February 2013 with an investment of £22m (US\$33.5m), supported by £6.5m of the UK Government's Advanced Manufacturing Supply Chain Initiative (AMSCI) grant funding. The Proving Factory will enable low-carbon vehicle technologies to be produced cost effectively in low volumes – up to a 90% price reduction compared with 'proof of concept' design – reducing the initial vehicle

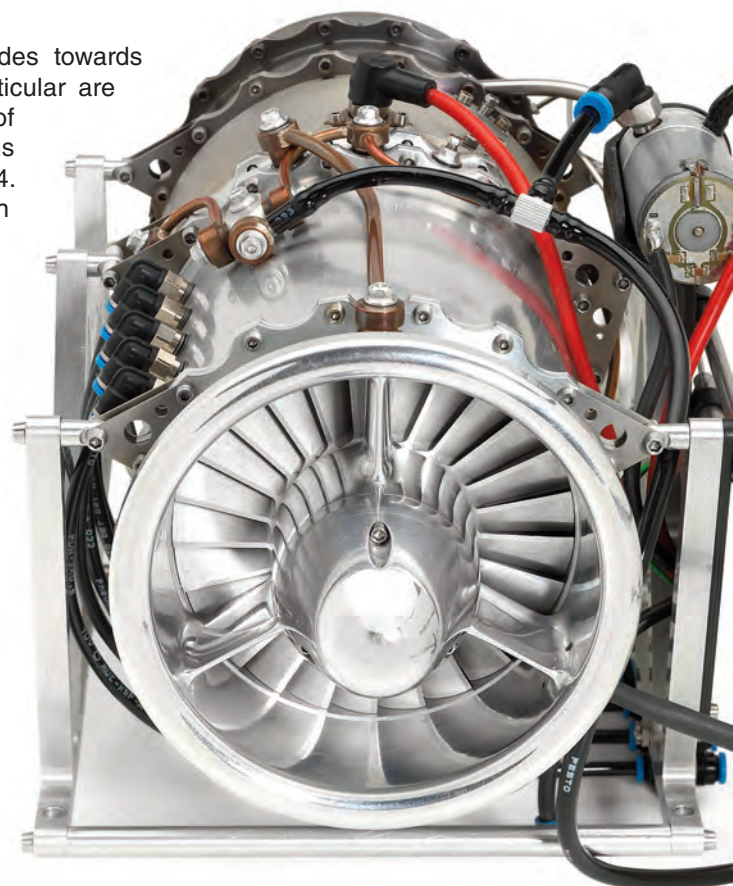

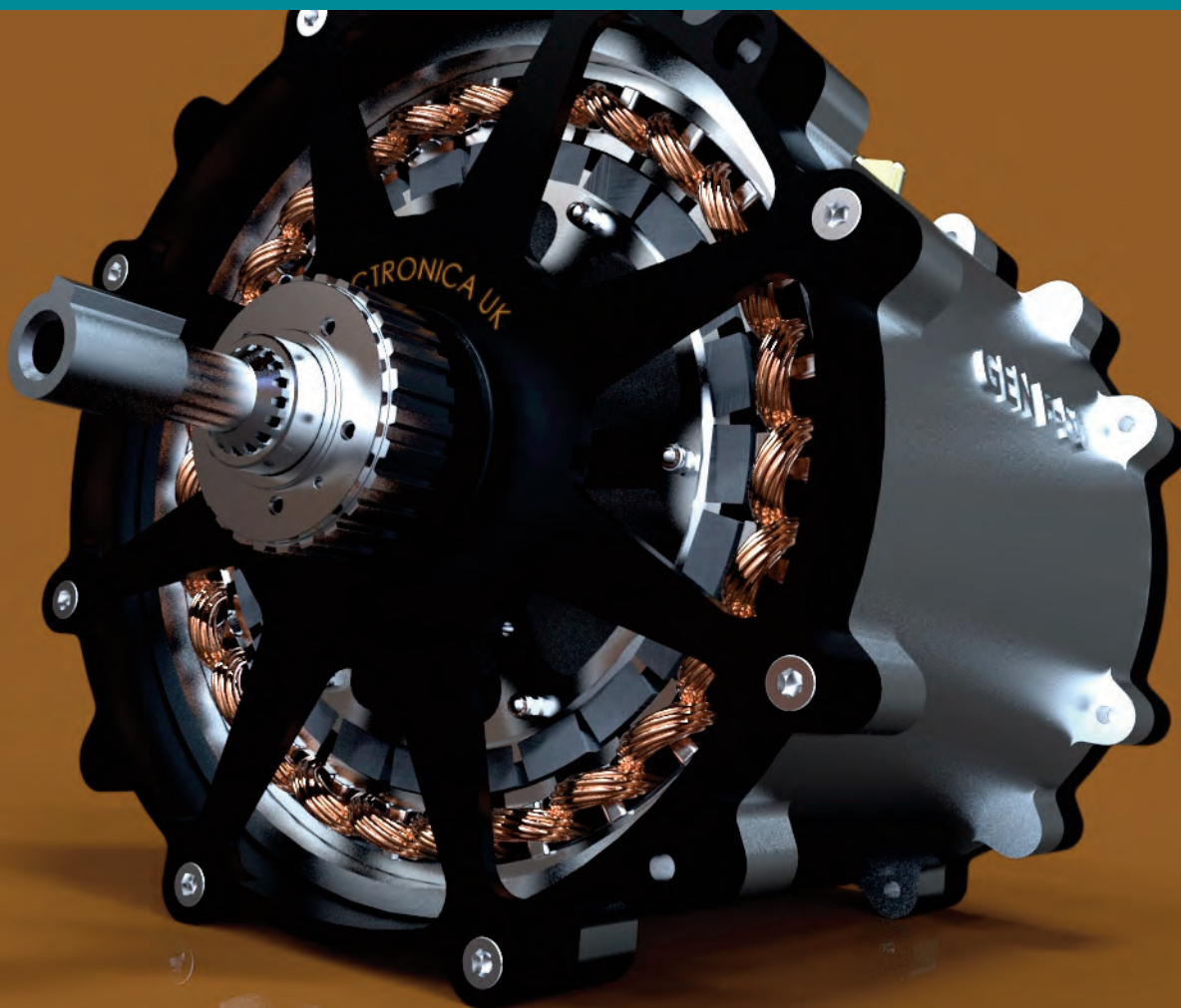

manufacturer investment required to adopt new solutions in future model programmes. Over the last two years, the project has developed into a business, with the creation of over 50 highly-skilled jobs and the development of assembly and component manufacturing factories to produce the new technologies. Production of the first technologies will begin this year.

For the technology developers, which are usually independent inventors designing one-off prototypes, The Proving Factory can turn their technologies into products, then make them for a vehicle manufacturer (OEM) application. For the OEM, The Proving Factory can take their orders, providing proving volumes of the innovative, low-carbon technologies they need to succeed in meeting emissions targets. For the UK Government, a major supporter, The Proving Factory is a national asset, aligned to the aims of the country's Automotive Industrial Strategy, the Advanced Propulsion Centre (APC), the Automotive Investment Organisation (AIO) and Automotive Council and a very successful example of growth and jobs supported by AMSCI funding.

The technology developers with which The Proving Factory is currently working are a great example of the range of innovations that are needed across the market:

- By shrinking a gas turbine engine into a light and compact package, Bladon Jets has opened up a new generation of range extenders for hybrid vehicles.
- Electronica has designed a novel implementation of coils into its electric propulsion generators which allows it to change the performance characteristics. For electric vehicles this means higher torque without drawing high current from batteries, increased drive range and higher acceleration.
- Magnomatics' MAGSPLIT power split device can create split hybrid systems which are 3-5% more fuel efficient than current rivals.
- Multi-speed gearboxes help electric vehicles to operate within their most efficient range, and Evolute Drives focuses on the development of such transmission systems.

OEMs need low-carbon technology solutions to meet EU and UK targets and the field is wide open for either

radical technologies that can reduce fuel consumption directly, or ones which replace those currently available but at lower cost, weight and volume. The Proving Factory provides the vital link between the technology developers with great ideas and the OEMs, turning ideas into products and then building the relationships that will get these products into service. By working with a variety of technology developers, The Proving Factory is developing a whole suite of low-carbon technologies that will meet the demands of the OEMs.

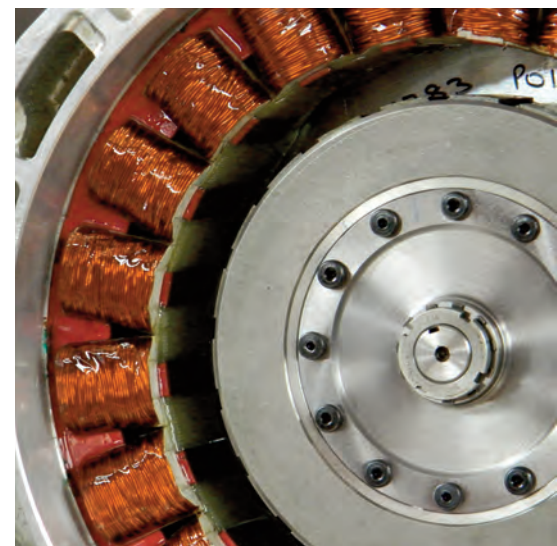

DRIVE CHANGE IN VEHICLE EXPERIENCE AND EFFICIENCY WITH INFOSYS SOFTWARE AND PLATFORMS.

OUR ENGINEERS ARE RESHAPING THE AUTOMOTIVE INDUSTRY WITH NEXT GENERATION IVI, ADAS, AND CONNECTED CAR SOLUTIONS, TO LIGHT-WEIGHT COMPOSITES.

INFOSYS SOLUTIONS ARE COUPLED WITH VALUE ENGINEERING, KNOWLEDGE BASED ENGINEERING AND PRODUCT LIFE CYCLE MANAGEMENT EXPERTISE.

WHAT'S AHEAD?

A strong ecosystem of cross-industry capabilities across mechanical, electronics, communications, software and analytics helps build more autonomous and efficient vehicles.

Infosys®

Infosys campus in the Electronic City area of Bangalore



Get the ecosystem right and connectivity can go global, says Infosys

Megan Lampinen talks to Sanjay Jalona about making connected car technology possible for all markets

In the world's developed automotive markets, connected car technology is an essential and assumed part of all new vehicle programmes. Car connectivity is now also becoming increasingly important in emerging markets. Indeed, Indian company Infosys believes that connectivity is possible for all markets, provided the right ecosystem is in place.

Megatrends spoke with Sanjay Jalona, Executive Vice President, Global Head, High-Tech & Manufacturing and Engineering Services at Infosys, on the global rollout of connectivity. Jalona

oversees one of the largest and the fastest growing segments at Infosys, the Manufacturing and Engineering Services business. The business has grown to US\$1.8bn and now accounts for 23% of total company revenues.

How is Infosys involved in connected cars?

Connected cars are something with which Infosys has been associated for a long time and at various levels. We provide a range of services, including



telematics strategy, embedded software and design, engineering services, complex event processing, building algorithms, Big Data implementations, Cloud implementations and analytics insights. We also provide enterprise integration and validation services. In addition, we invest in research and development as part of our Center of Excellence for the Internet of Things, and Infosys Labs to help our clients implement complex use cases and programmes.

Can you please provide some examples of your company's involvement in connected car technology developments?

We recently partnered with Toyota on a Driver Awareness Research Vehicle (DARV) project. We used a combination of Microsoft Kinect, Microsoft Surface tablets and Pebble smart watches for a number of use cases on driver distraction avoidance. We have built an ecosystem of partnerships with Bosch Software Innovations, PTC, Oracle, SAP, Tableau, DigiLogic, Gemalto and Pega to enable our connected car solutions.

Toyota Driver Awareness Research Vehicle





How is the adoption of in-car connectivity progressing in the world's major markets?

Car connectivity can be tethered, integrated or embedded. Tethered refers to connectivity through the smartphone. When we talk about integrated, the car's dashboard screen acts like an extension of the smartphone's screen, such as CarPlay and Android Auto. In embedded systems, a SIM card is embedded within the car's communication module. Embedded gives OEMs the flexibility to differentiate from their competitors.

In your experience, which is proving most popular?

Our perspective, based on what we have observed in North America and Europe, is that luxury brands will opt for embedded SIM cards, which offer strong brand differentiators in terms of unique features. For the lower-end car segments, customers will have the option to go either for the tethered option or integrated options.

Safety or convenience – what is the stronger force in driving connectivity developments?

I think both. Safety is paramount, and there can be no compromise on safety. Given that, we are talking about mobility in a vehicle under unknown conditions, such as road, weather and the movement of other vehicles. It is clear that safety trumps convenience. However humans, by nature, are always in search of convenience and it is a key criterion for customers to choose a vehicle.

Do you think the introduction of semi and fully autonomous driving might change this?

No. With the drive towards autonomous vehicles, the focus is on making vehicles safer for humans. This is the ultimate goal towards which the industry is being driven. Convenience comes along with technological advances and if it helps OEMs to differentiate their products, why not? However, the convenience features are more easily replicated,

while safety features provide a long-term differentiation.

What role will government support play in furthering in-car connectivity?

Governments will play an important part in the transition and acceptance of connected car services. We can see this happening in Europe with eCall. In North America, NHTSA is already leading a number of safety innovations around vehicle-to-vehicle connectivity and autonomous emergency braking.

Do you think connected vehicle technology will eventually be a possibility for all regions?

Yes, but in the long term. The existence of the ecosystem is of great importance, and this ecosystem consists of different stakeholders – governments, customers, automotive OEMs, vendors or partners, and third party service providers.

We see the governments in Europe and the US taking proactive measures and introducing bold initiatives to make connected cars a reality. They are enabling companies to experiment and are changing laws to accommodate new technology advances. They are even investing in major programmes, along with industry and academia, to further the cause of a safer future on the road. Other regions may take similar steps but may take longer to realise them.

How does the cost of this technology impact its adoption?

With advancements in manufacturing and a widening usage base, the technology costs are dropping quickly as well, so it would not be too long before these become the basic norm in more markets around the globe.



Apple CarPlay in the new Mercedes-Benz C-Class



CATALYZING CHANGE

Redbend catalyzes change in the connected world.

We keep more than two billion automotive, mobile and IoT devices continuously relevant with over-the-air software updates, virtualization and device management services.

Please visit us at Stand #7 to learn more about how we can help keep your devices relevant and increase brand loyalty.

www.redbend.com

redbend

How, not why, is the question now shaping connectivity development

Redbend sees over-the-air updates as the key to delivering the connected car

By **Rachel Boagey**

By around 2020, most cars in Europe and the US will be connected. Until then, car buyers will continue to ask why the digital lifestyle they enjoy today is not available in their car.

Yoram Berholtz, Director, Business Line Manager, Automotive at Redbend Software, believes it's no longer a question of 'why a connected car?' but 'how do we deliver one?' Berholtz spoke to *Megatrends* about how the industry can tackle ongoing connectivity challenges.

Connected cars present an interesting challenge to OEMs – not only must they deliver a service that consumers expect, but they must keep their cars up-to-date, delivering the same user experience that people are used to with their mobile devices.

"In the future, drivers will not be happy to return to a dealer for a software update. Instead, like in a mobile device, they will expect the ability to update it

over-the-air (OTA). This is where Redbend comes in," Berholtz explained.

The car is fast becoming the largest consumer electronic device, thanks to smartphone-like software management technology and OTA software and firmware upgrades. Redbend's technology is already available in more than a million cars, trucks, and heavy machinery, enabling effortless wireless software updates. And in January 2015, Redbend was acquired by Harman in a move which will position the company even more aggressively into OTA service delivery, making it clear that OTA updates are here to stay.

The circle of life

A key challenge faced by OEMs is delivering a new car with the most up-to-date software, both during production and during the finished vehicle shipment, explained Berholtz. "When the car is in production, there is some delay while installing the

subcomponent into the car on the production line. During this time, there may be software updates that need to be incorporated into the ECU," he explained.

Software updates carried out OTA can also aid the industry in the shipping of new cars; an ocean-bound car carrier can be at sea for weeks before it reaches port, with a further delay between the port and the dealer. "During this time, there could be new software updates, just as there could when the car reaches the dealer, as well as once it is in the hands of the consumer."

Fast-track to improved connectivity

The OTA update capabilities offered by Redbend mean that the system will only update what Berholtz describes as "the delta," meaning that only the changes between the current version and the new version are updated. "We enable this as it shortens the update period by more than 70%, a very



important aspect for an OEM to maintain customer satisfaction.” Satisfaction can also be maintained via bug fixes and software upgrades at a time suitable to the customer; and of course, avoiding any need for the consumer to go out of their way to visit the dealer can be considered a source of high customer satisfaction.

As the car’s ability to connect to the outside world grows, so too does the amount of data it needs to store and handle, providing another use case for OTA updates. “A software update is a necessity when there is a lot of code. If you think of an old Nokia phone, the number of software updates was minimal. But now on an iPhone or an Android, software update occurs every three or four weeks, because the number of lines of code has since increased tenfold.” This now also applies to a car, explained Berholtz. “The fact that there is an increased amount of code inside the car means it is vital to have the ability to update the software and data and make it fresh.”

Shut that door

The increasingly connected car also opens the door to malware and viruses. While Redbend is not a security expert, the company is working in partnership with industry experts such as Cisco to build systems that will close the door to those ‘unwanted guests’ with the ability to digitally sign each of the packages that are going to the car, and to detect if this signature is correct. “If the signature is not correct, then the system will not perform the update,” says Berholtz. “If the client detects that this signature is correct, then we will continue with our update process, so it reduces the risk of a bug or malware getting into the car via the update process.”

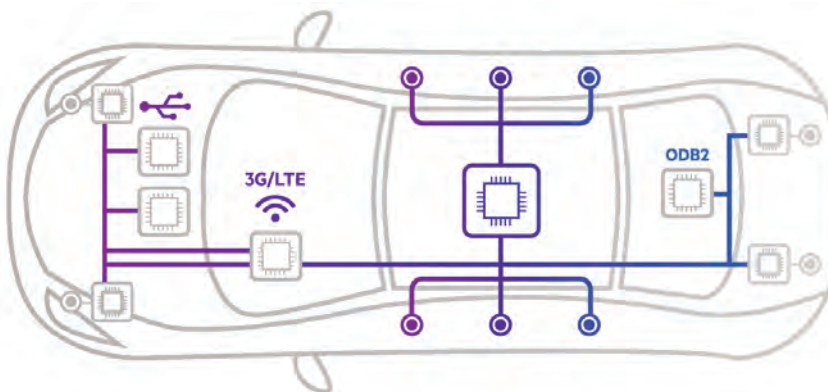

Standards, standards

From fuel efficiency to electric vehicle (EV) charging, standards in the automotive industry are being demanded by multiple parties to enable easier and quicker product development. In the case of connectivity, speeding up and enhancing the ability to keep cars up-to-date will be vital in the coming years. For this reason, said Berholtz, Redbend is a member of the GENIVI Alliance, which promotes the adoption of an In-Vehicle Infotainment (IVI) open-source development platform. This membership allows the company to collaborate with the automotive industry in developing standards that will assist OEMs to reliably and efficiently manage and maintain the growing levels of software in cars.

“The goal is to come up with a type of middleware that will help the OEM and the Tier 1 to reduce time to market. This is possible due to standards which could provide say 80% of development readiness, leaving 20% for the OEM to adapt in order to differentiate itself from the competition,” said Berholtz. “Our work with GENIVI will create a package that will help OEMs to reduce their development cycles and focus on

security. We think our solution is something that can be aligned with GENIVI to manage and improve in-car software updates.”

Looking to the next ten years and beyond, Berholtz explained that OTA updates will play a big part in the advancement of the connected car. “OTA updates will be used for bug fixes as well as to avoid big recalls.”

Big Data will also play an important role over the next decade. “It’s not only for understanding the habits of the driver, but to help car manufacturers better understand what is happening inside the car and which parts are not working correctly, as well as taking this analytic information from the car to serve the needs of the customer. Beyond that, another area is data analytics, where we take the information from the infotainment applications and hardware, and deliver it to the OEMs’ Big Data servers. Redbend will play a role in the future of all of these key areas.”

So how does the industry go about delivering the connected car? That is a question still waiting to be answered, but Berholtz is certain that Redbend “will make the foundations that the industry needs to reach it.”





WITH GARMIN INFOTAINMENT SOLUTIONS, IT'S THE JOURNEY AND THE DESTINATION.

As the global leader in satellite navigation, we're uniquely able to develop and serve your company's infotainment needs—from simple, removable devices to full-vehicle systems with robust passenger-entertainment options. We design and manufacture complete hardware and software solutions that combine award-winning, best-in-class navigation with easy-to-use functionality, featuring media players, vehicle systems and HVAC integration and phone, calendar and text connectivity. And we even incorporate third-party services, like CarPlay and Android Auto. No wonder we're redefining the industry's vision of what infotainment can do.

To learn more about Garmin infotainment solutions customized for your business, contact your Garmin Automotive OEM Sales Rep, visit Garmin.com/infotainment or email Mkt.Autooem@garmin.com

GARMIN®



Navigating towards a safe connected car

Rachel Boagey and Garmin's Kip Dondlinger discuss the challenges of making cars connected...and safe

The car of the future will require advanced connectivity and navigation, the ability to wirelessly update, and an intuitive User Interface (UI) that meets consumer needs for a safe and connected drive.

By incorporating navigation and safety into its development plans, and offering software and hardware infotainment platforms that combine advanced navigation and smartphone integration, Garmin International aims to provide users with an always-connected lifestyle.

Kip Dondlinger is Product Manager, Automotive OEM at Garmin, a role that entails planning the company's next generation platform and products specifically for automotive OEMs. Dondlinger is also responsible for putting together Garmin's feature and product requirements, and leading the User Experience team which develops UIs and carries out customer research, evaluating and ensuring the usability of Garmin's products to reduce driver distraction, as well as setting new standards for infotainment integration and usability.

In a recent interview with *Megatrends*, Dondlinger spoke about the future of

navigation in the eyes of Garmin, and how the company can develop not only as a navigation provider, but as a key part of the connected car community going forward.

Battling for attention

While recognising the need to make the car more connected, Garmin also notes that there is a fine line between providing customers with the connectivity they require, and making sure they're not distracted from the task of driving. "It's something that we've been focused on for a number of years now, and there's no one single approach to making the car connected in a safe way," noted Dondlinger.

"I personally take this very seriously," he explained. "You still see many people using their smartphones while driving. We are very much focused on identifying those situations and use cases that tempt people to interact with their phone while they're driving. We can then make those use cases accessible in a far safer way through the head-unit."

To address this, Garmin has created a solution which provides advanced

infotainment technology alongside advanced driver assistance systems (ADAS), to help solve the diverted attention dangers often associated with in-vehicle infotainment.

"The ultimate goal is for the driver to have very little interaction with the touch screen, and very few steps in order to complete the task," he noted. "We do this by making sure the system responds to the pace of the driver, and he doesn't feel pressured to complete a task in a certain timeframe. Driving needs to be the first priority, so the driver should decide the pace, not the system."

Garmin's K2 platform was developed by the company's automotive group and is a fully customisable and scalable solution to meet the needs of OEMs, as well as the needs and safety of the driver. "As systems become more complex, they can become more and more difficult to use," Dondlinger commented.

Today, he noted, in some vehicles that support applications such as OpenTable or Yelp, the driver has to exit the navigation application and open other applications to make, for

example, a dinner reservation. “With K2 and our navigation systems, though, you’ll be able to access that type of functionality from within the navigation system. It means there are fewer steps for the user, so that it’s much easier to find a destination and do other things in a third party application without having to manage separate apps.”

A friendly voice

The company also has its own in-house speech recognition team, and Dondlinger said Garmin’s expertise in this area helps to create easy-to-use solutions for the user. “We work with partners like Nuance, but also apply our own solutions on top to make things more usable. Speech features are something that people don’t give too much consideration to until they actually have it, and it’s really nice to be able to get guidance in a way that is more like the way people think than the way a computer thinks,” he noted, adding that the system is an easy to use and understandable solution for navigation purposes: “People often don’t have a good sense for what 100 feet is, but if the system was to say ‘turn right at the second traffic light,’ or ‘turn right at McDonald’s,’ it becomes very easy for people to understand and comprehend.”

Pushing a wireless future

Dondlinger believes that the increasingly connected environment will significantly improve in-vehicle navigation. “The days of loading software onto a system yourself will soon disappear, as we see more and more systems that do the same things

people have come to expect through their smartphones and their tablets. That is, to always have updated software and the latest information.”

While embedded systems have traditionally been slow to update their data, Dondlinger explained that this will soon change when over-the-air (OTA) information updates are introduced to built-in systems. “We’ve got technology coming in our next generation navigation core Gemini, which enables you to push smaller files, map updates and POI updates to vehicles over wireless networks,” he said. “It will mean we are very frequently and affordably able to give users the latest information in their vehicles.”

Dondlinger also explained that one of the biggest problems concerning in-dash navigation systems is consumers being unhappy with the map and POI information not being up to date. “With Gemini, we have redesigned navigation from the ground up so that we could do the types of OTA updates people want in a way that doesn’t consume a lot of bandwidth,” he added. “We can send out updates based on geography or updates on parts of the road network that have changed, for example. The companies that succeed in infotainment will be the companies with the capability to push these types of updates to vehicles. It’s something that will really change embedded solutions,” he suggested.

End-to-end experience

With increasing consumer reliance on smartphones, automotive companies have an opportunity to develop

software that helps bridge the gap between infotainment used in cars and the applications that drivers use before and after their journeys.

For this reason, Garmin is working on an end-to-end experience for customers for when they leave their car and its navigation system, so that they have ‘last mile’ information transmitted to their phone. “If the user is walking to a specific airport terminal for example, our system can route them specifically to where it is they want to go. Once they turn off their car engine, that information can be instantly transferred to a portable device so the driver is not left in the dark about the rest of his journey,” Dondlinger said. “There are opportunities both within and outside the car to really connect the user to their vehicle and to the navigation information that’s available.”

A two-way street to autonomy

Looking to the future of the connected car, Dondlinger pointed out that partially autonomous vehicles will continue to advance, and that the supplier will support more two-way information when it comes to maps. “Maps will become more up-to-date because vehicles on the road are providing updates as they drive,” he said. As roads change due to construction, and as weather conditions change the road, therefore, cars will require real-time accurate data that gets fed from the vehicle to the network and back to other cars. “That still may be a number of years out, but we are looking at how to make that real and how to make maps more detailed.”



Performance advancements in Garmin’s new Gemini navigation core allow for the integration of realistic and beautifully rendered 3D graphics

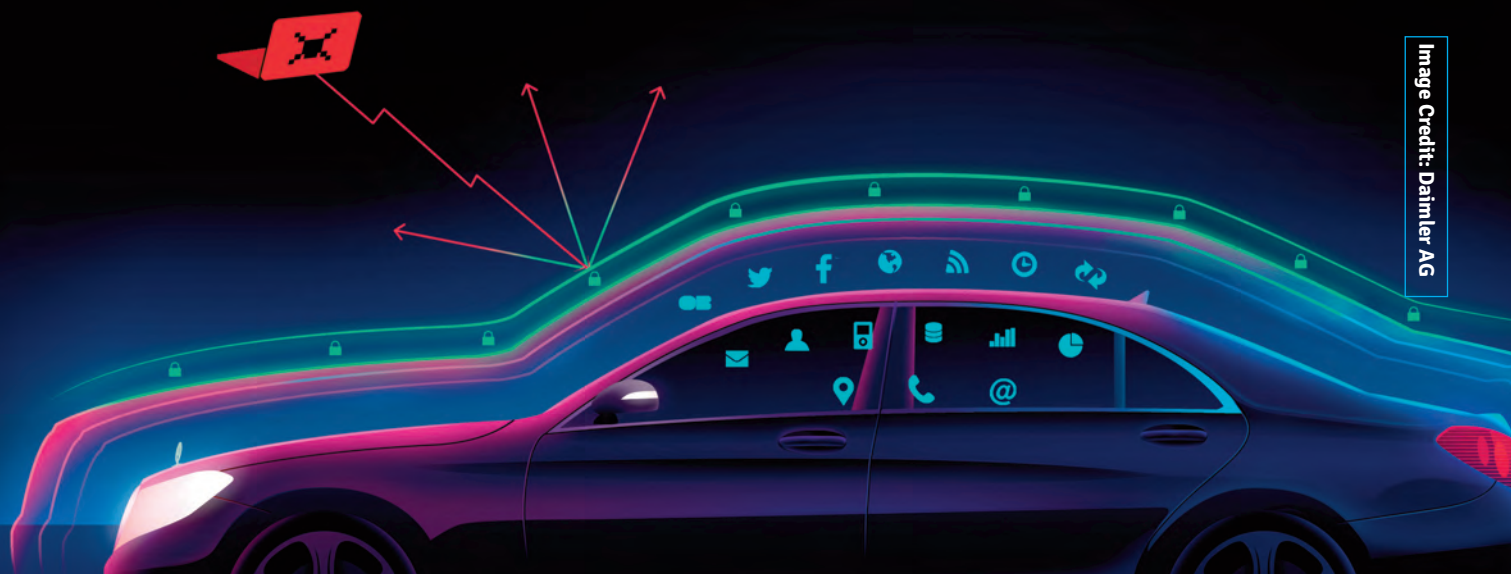

How to tackle the car hackers

Green Hills Software's Dan Mender talks to Megatrends about the need to protect the connected car from data hacking

By **Freddie Holmes**

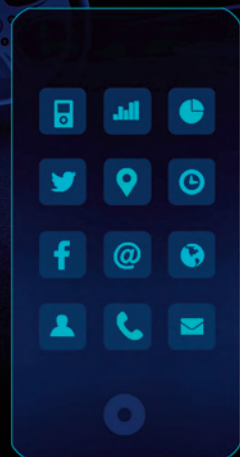

According to ABI research, 60% of new cars shipped globally will feature connected car solutions by 2017. While this offers countless exciting opportunities for infotainment, there are growing concerns that as these vehicles become more software-based, the opportunity for hackers to get into the car's system increases.

Evolution of the industry

Indeed, security is one of the major connected vehicle challenges yet to be addressed – and solved. “In reality, today’s IVI (in-vehicle infotainment) systems really cannot deliver a secure connected car. How do you actually architect the system? That’s where our expertise is front and centre for the automotive industry,” says Dan Mender, Vice President, Business Development at Green Hills Software (GHS). The company has been involved in the automotive industry for more than 20 years, and is seeing an increased need for software capabilities in automotive applications.

GHS works with OEMs and Tier 1s to help their customers design systems that

are secure and cannot be hacked. The company is actively involved with the National Highway Traffic Safety

Administration (NHTSA) on its Security Credential Management System, a defined solution put in place to securely



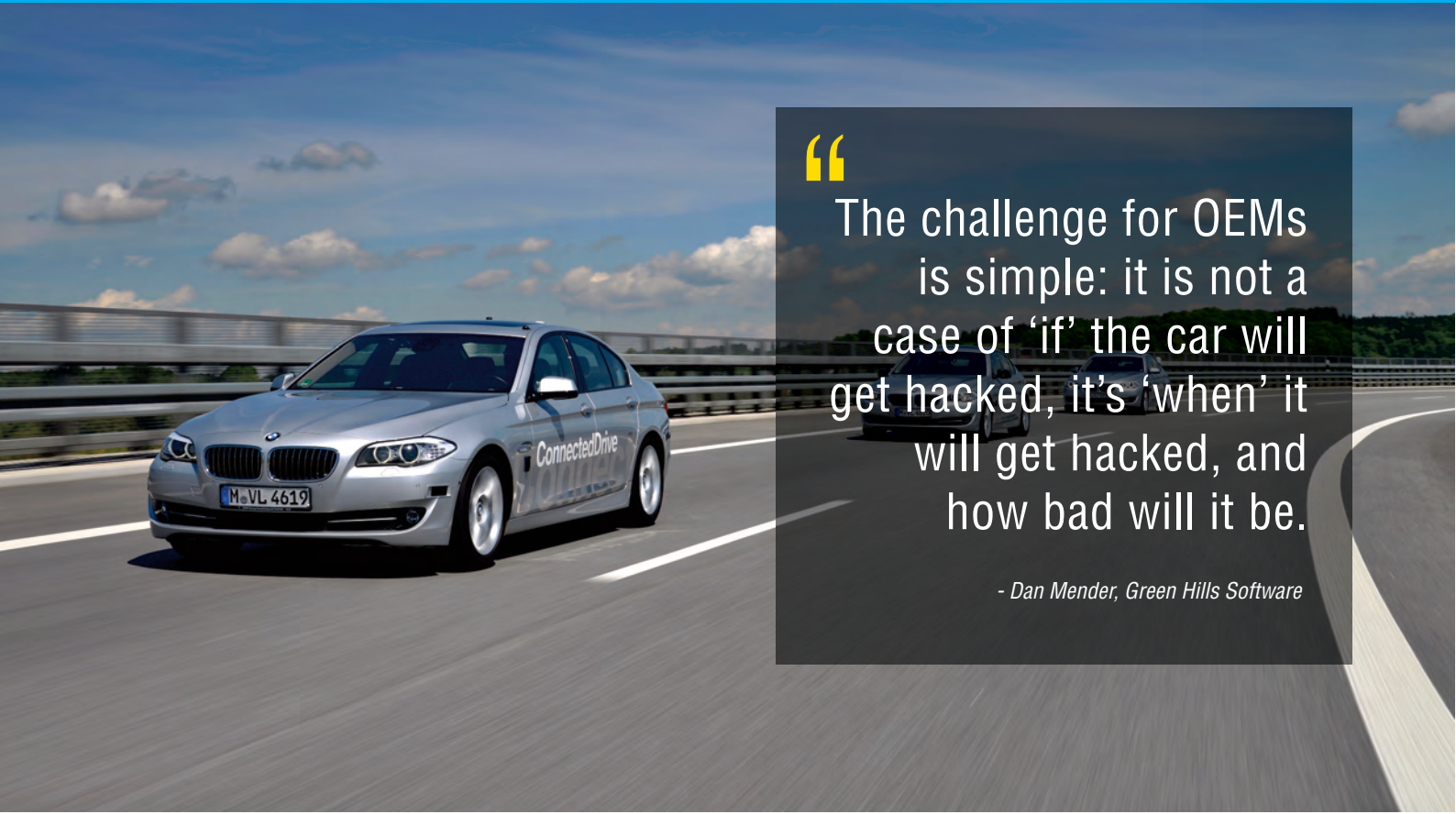

“

The challenge for OEMs is simple: it is not a case of ‘if’ the car will get hacked, it’s ‘when’ it will get hacked, and how bad will it be.

- Dan Mender, Green Hills Software

verify the credentials of information shared between vehicles and infrastructure.

Mender explains that IVI systems will take advantage of the fact that the car is connected, but they are not designed in a way that they can provide secure communications: “It’s definitely a holistic approach. The challenge for OEMs is simple: it is not a case of ‘if’ the car will get hacked, it’s ‘when’ it will get hacked, and how bad will it be.”

Specific data about vehicle use is becoming increasingly shared by connected cars today. Hardware can be plugged into the vehicle diagnostics which wirelessly communicates specific vehicle data about speed, location and how often the vehicle is used. This is very specific and personal user information, Mender points out, “but that data isn’t protected.” The car as we know it is becoming more of a software-centric platform, and OEMs now have to look at designing a vehicle as “a system of systems,” he says. GHS aims to design systems that have the security architecture needed to ensure there are no “back doors” that allow an outside source to subvert and take over that system, he adds.

Hacking away

It is very easy to gain access to – and hack – this data, Mender observes. “If

someone wanted to go and collect vehicle data from various insurance companies that were using those modules, they could collect that data and use it however they liked. It wasn’t designed with any security in mind, and that is a major problem.”

This “major problem” will be exacerbated as the level of automotive connectivity increases, and the car’s ability to connect with more devices grows. Mender envisions the car of the (near) future being able to generate a profile based on the data gathered from a driver’s movements. This will include recommendations based on where the driver usually travels, their hobbies, and a virtual ‘to-do list’.

“That’s personal data. If the car is starting to learn about a driver’s likes, what they like in the vehicle, the music they listen to, which shops they tend to visit, and where they buy their coffee, it will be gathering a lot of information that is going to become very personal. It all sounds very good, but it could be very intrusive if it is not protected properly,” he says.

Keeping the personal, private

This raises the question, should drivers have the ability to ‘opt out’ of providing social data via the connected car? Implementing a secure ‘opt out’ function, and ensuring that information

is not being sent at all, are two different things, Mender suggests. “You can tick a box that says ‘I don’t want this information going up to the Cloud,’ but how do we guarantee that the information isn’t actually being sent?” he asks. “Every time I go on Google and search for a flight, the next time I go on Google it offers me flights for that location because it noticed that I did that. The car will be doing the same thing in future, and drivers are going to be under threat,” he continues.

Predictable, solid, separate

GHS works in tandem with OEMs to consolidate critical vehicle functions with comfort features. Within the area of IVI there are companies like Intel working with GHS to focus on the consolidation of advanced driver assistance systems (ADAS) used in autonomous vehicles. OEMs need to be able to ensure that a comfort feature like IVI does not react in an unexpected way to the critical systems that steer, brake and manage the vehicle’s movement through autonomous driving.

Mender believes that the next step for the industry is to take away the threat of any erratic disruptions to autonomous driving as a result of a system hack, and ensure that systems in the connected car are predictable, solid and separate.

REDUCE PER-UNIT PRODUCTION COSTS WITH GREEN HILLS AUTOMOTIVE SOFTWARE PLATFORMS

In-Vehicle Infotainment

Secure virtualization framework for Linux and Android built on the INTEGRITY RTOS enables virtualized and real-time safety components to run concurrently.



Instrument Clusters

Support diverse safety levels, 'instant-on' boot, and 2D/3D graphics. Reduce costs by consolidating AUTOSAR software on INTEGRITY.

Advanced Driver Assist Systems and Safety

Manage the increased complexity of multiple sensors feeding multiple applications and outputs, at diverse safety levels, on INTEGRITY RTOS.



Powertrain, Chassis and Body Electronics

ISO 26262 ASIL D qualified compilers and tool suite. Essential for any project with ISO 26262 requirements.

Green Hills Software provides the world's leading automotive companies with software platforms. To reduce the production costs of your next project, visit www.ghs.com/p4a

Coming
soon!

**All new cars
will be
connected
by 2025.**

Check out our free guide to
the companies making that happen.

<http://guidetoconnectedvehicles.com>

Tech development is disrupting traditional auto industry relationships

The automotive industry's switch from HTML5 to Qt is good news for ICS, as the company's COO, Mark Hatch, tells **Megan Lampinen**

Developments in connected technology are reshaping the automotive landscape, as well as the relationships among industry players. ICS is seeking to lead the way in terms of user experience. The company provides integrated custom software development and user experience design for touchscreen, mobile, medical, embedded and desktop applications. About four years ago, it entered the automotive sector and is now involved in development of infotainment systems for vehicles.



"At this point, we have four different in-vehicle infotainment (IVI) projects underway. It's a major change in the business," Mark Hatch, ICS' Chief Operating Officer, tells *Megatrends*.

Inflow of new technology

Hatch believes the flow of new technology into the industry is leading to a change in traditional relationships between suppliers and their vehicle manufacturer customers. "What's happening here is a disruption of the traditional kind of OEM/Tier 1 relationship. All this new technology is coming in from multiple directions. It's coming in from the Internet of Things, which is the connected car aspect. It's coming in from Apple and iPhones and people's expectations of a user interface. It's coming in from set-top boxes."

Hatch explains that the convergence of these forces is resulting in an opening up of what was traditionally a closed industry. "It's opening up this industry in a way that it's never been opened

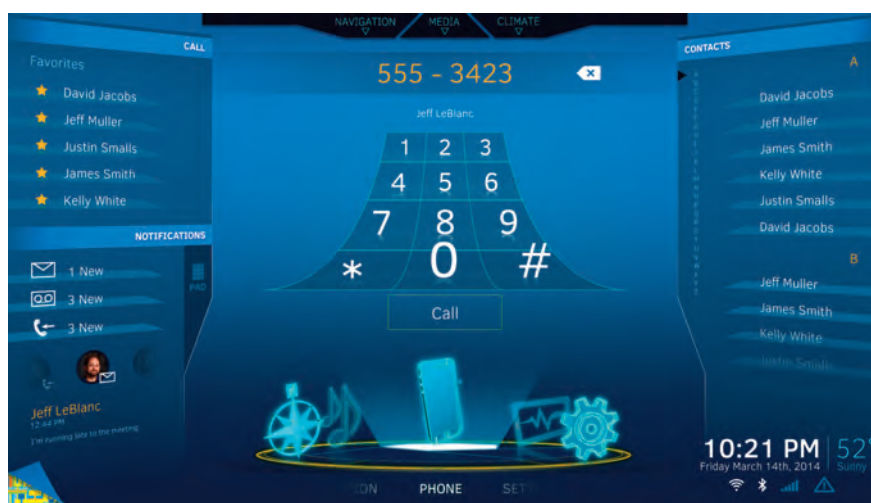

before. It was a fairly tightly integrated industry for many years. And now with all this new technology suddenly coming in, all those relationships are being shaken up," he explains.

Competition, moves in-house

As the industry responds to these rapid technological developments, Hatch believes the level of competition will heat up. He expects to see more Tier 1 suppliers start to subcontract work out more effectively. However, Hatch also raised the possibility of OEMs taking more capabilities in-house.

He points to the move by a number of vehicle manufacturers to set up local technology development units in Silicon Valley, noting: "OEMs from Detroit, Tokyo and other major vehicle manufacturing locations are going to Silicon Valley and opening up labs there... I see the brands or the OEMs directly getting involved with this technology, and not necessarily always using the Tier 1 supplier," he says. Financially, this approach would involve "putting all the money up-front in terms of the costs of the development versus pro-rating it over the unit sales. The financial guys may get involved at

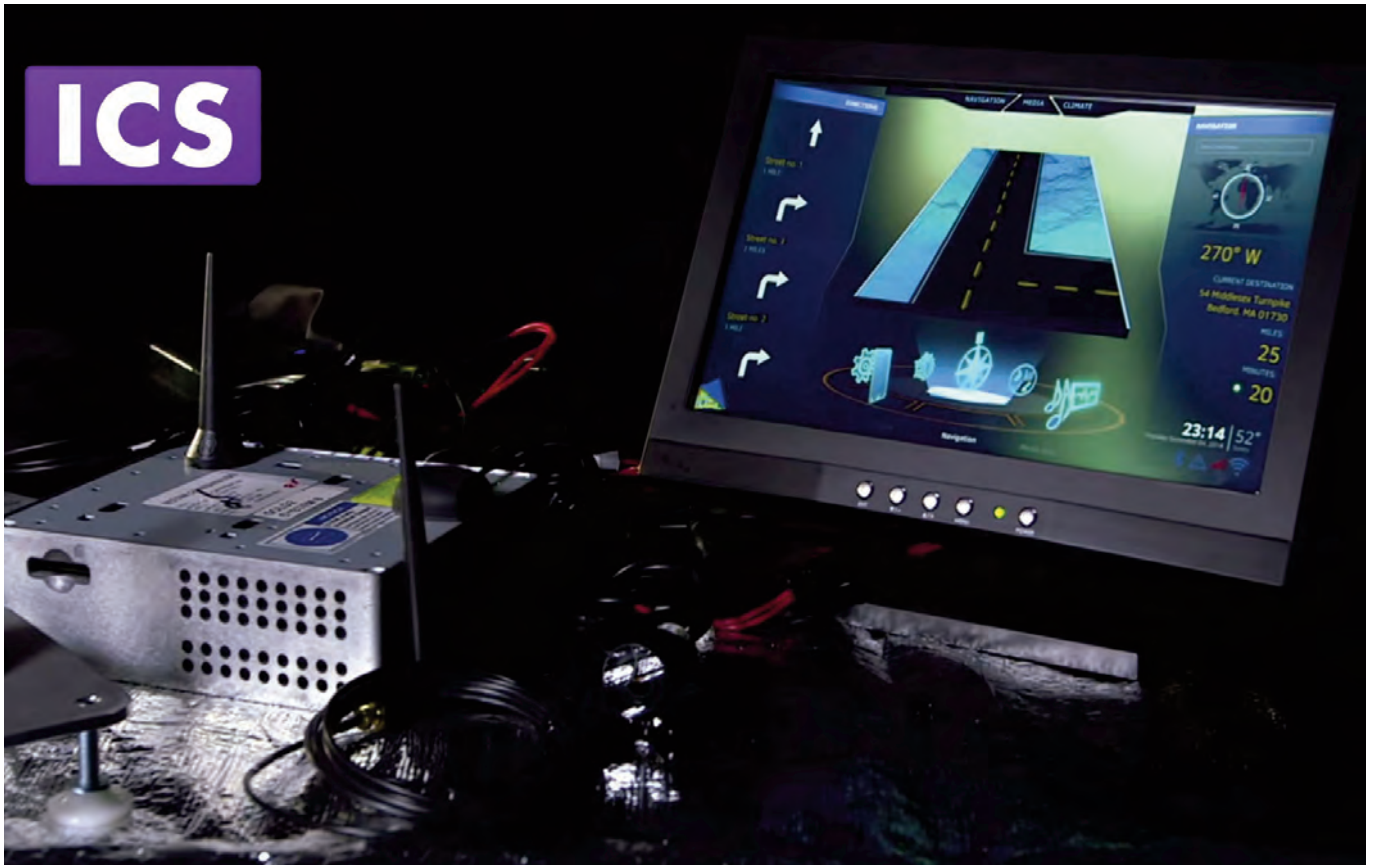

some point on this in terms of helping figure out which way these things have to be organised. I don't know if it'll continue or not, but it's certainly happening now."

HTML5 vs Qt

Among the many new emergent technologies, several are fighting for dominance. In terms of application development environments, HTML5 and Qt have been rising in popularity, but Hatch sees Qt as pulling solidly ahead. "About two years ago there was a big switch to HTML5. One of the things we're seeing now is a switch back to Qt," he explained. In fact, all of ICS's automotive projects at the moment are Qt-based. Hatch's responsibilities include management

of the Qt business, covering both products and consulting services. "For one of our initial research projects with Intel, we originally tried using HTML5 and were just not able to get the capabilities that we could with Qt. I don't want to forecast that as a forever truism, because the only thing about technology is that no technology lasts forever. But at least we're seeing a trend back towards the use of Qt."

Challenges ahead

For ICS, this trend is "really good news" because all its 125 engineers are focused on Qt. "As that trend moves back into the auto industry from a technology point of view, that's great news for us. If you need to staff up a

large project, you can't do that one person at a time. You have to go somewhere where you can get 20 people onto one project. And that's what we can do," he adds.

For ICS, the challenge now is responding intelligently to the feast of opportunities on offer. "The US economy is in an expansion mode. As a result, from a business point of view, we have more business than we'd previously expected month to month, which is great. And the challenge here for us as an organisation is to make sure that we continue to keep up the quality and not be seduced by the volume."

Getting the right employees on board, and accepting the right projects, are both part of this challenge. "When you hire somebody, you're making a long term commitment. Our challenge at this point is to hire the right people. At the same time, it involves trying to pick the right project, and avoiding projects which don't go in the right direction strategically," he says.

For ICS, much attention this year will be focused on making itself known in an increasingly crowded segment. "We have multiple projects, but we're not a household name," he said. "Our challenge is one of increasing our visibility by successes. We're not alone here."





www.ics.com

Custom IVI Solutions



Software Development and User Experience Services

- QNX[®] CAR Platform
- Intel[®] In-Vehicle Solutions
- Apple[®] CarPlay Integration
- OpenMobile Android Compatibility Layer (ACL) Integration
- Custom Android App Development for IVI Applications
- Navigation / Voice / Multimedia Audio & Video

Can we build one for you?

www.ics.com/ivi

(617) 621-0060

info@ics.com

Register
Now!

What's next for **India's** **passenger car and** **commercial vehicle** industries?

Find out at Automotive Megatrends India
in Pune on December 2-3.

<http://automotivemegatrendsindia.com>

Smart maps show the way for the connected car

*Intelligent mapping is essential for the future of the connected car, as TomTom's Charles Cautley explains to **Freddie Holmes***

Close to a billion people rely on TomTom maps, says Charles Cautley, Managing Director of Maps at TomTom.

Cautley is responsible for TomTom's map products that power an array of applications developed by its partners in automotive, mobile, Internet, location-based services and geospatial solutions. From this position, he can see first-hand the fast-moving world of consumer electronics, the growing use cases for location data, and the development of products needed to support these future use cases. The result is that TomTom is creating the mapmaking engine that supports connected cars, automated driving and, by extension, the Internet of Things (IoT).

Connected car

To a wide extent, the connected car has already been a reality for several years. TomTom sold its first connected portable navigation device (PND) in 2007, and installed the first connected built-in system, in a Renault vehicle, in 2009. Cautley explains that the primary benefit of having connected cars is "the possibility to deliver car-centric value-added real-time services." TomTom Traffic, for example, provides real-time 'jam' information and avoidance, and today, with the development of 4G LTE networks, connectivity is becoming a commodity. This has increasingly enabled the development of advanced cloud-based services. Ultimately, he says, "consumers are hyper connected, they want to have a certain continuity in their digital life, and they expect their vehicles to be an extension of this

digital life. We need to provide a seamless experience to them, but it is a formidable challenge for companies like TomTom."

Consumers have become increasingly dependent on reliable access to Internet-based applications on the move, wherever they are. Because of this, the industry is working to ensure cars can stay connected, even in areas with poor reception.

Cautley explains that "connectivity enables great use cases, and in most cases the GSM coverage is excellent in a majority of the mature markets." At TomTom, the company believes in a 'hybrid approach' to embedded navigation, where systems make the most of a data connection when available, but will also continue working when there is no GSM signal.

Smart maps lead the way

With the mass-commercialisation of 3G technology spreading to consumer devices, there has been an ever expanding need for people to remain connected wherever they are, with the car gaining increasing importance. The idea is simple: every step you take, every move you make, you'll be connected. Mobile phones are no longer just a form of communication, and cars are no longer just a form of mobility, but more so a computer on wheels, or as some have even argued, a smartphone on wheels.

Part of the appeal of seamless connectivity is the ability to accurately navigate around the immediate environment. For the automotive



"Highly accurate and up-to-date maps are required to support the evolution in location awareness where everything is becoming connected" - Charles Cautley

industry, this extends further than satellite navigation, and for TomTom, new opportunities are presenting themselves as developments in the autonomous car and electrified powertrain increase.

"Highly accurate and up-to-date maps are required to support the evolution in location awareness where everything is becoming connected," Cautley observes. "Connected cars are part of the IoT family and we have created the mapmaking engine that supports this evolution." He predicts that real-time map updates will enable the connected car to know exactly where it is, what is around it and where it is going at all times. "The up-to-date, highly accurate map will also enable autonomous driving," he adds.

To ensure maps have a high degree of accuracy, TomTom relies on 'intelligent



map-making, and to support this, it has developed an efficient hybrid approach that combines professional map-making methods with community input, with a focus on fast cycle-times and quality assurance. Through this hybrid approach, TomTom taps into local teams of skilled map technicians located across more than 40 countries, and a fleet of mobile mapping vans that drive the streets every day.

Stay updated

With the growing dependence on in-car navigation systems, maps can no longer be out-of-date. Using mobile mapping vans alone to keep maps up-to-date is too slow, Cautley says, and using community input alone has risks. There are three main challenges, he explains. “First, we have to allow for fast cycle times from real-world changes through to the end-user experience via a closed-loop system. Second, we need to deliver this change with the high

levels of quality assurance that consumers expect.” Finally, data use also plays a key part in keeping maps up-to-date. The processing of the sensor data used in the map needs to be efficient, the sending and receiving of data needs to be optimised, and the processing of large volumes of data from all the connected devices needs to be tuned “to maximise the value that can be extracted back to the devices.”

“We also have a growing community of hundreds of millions of users that share map feedback with us as changes in the real world are detected. We receive more than 200,000 consumer reports monthly and our database of anonymous GPS measurements is at 12 trillion probe-data-points and growing,” Cautley explains.

TomTom makes hundreds of thousands of edits to its maps every single day, rapidly shortening the time between detecting changes in the real world and updating the map on an end-user’s device. “With this seamless process, we will always be the first to publish the most up-to-date and accurate maps in the market. Today our legacy navigable map products are released every three months. Going forward, we will release our maps much more frequently; monthly, weekly and eventually releasing updates in days – and for some map features – hours.”

What next?

With the prospect of self-driving cars and vehicle-to-everything (V2X) connectivity in the very near future, the demand for highly accurate maps will only increase further as the use cases for up-to-date maps increase. According to a new report carried out by Juniper Research, some 700 million cars are expected to be on city roads around the world by 2019. Future ‘smart cities’ are set to reduce congestion through digital technology such as road sensors and software systems, and communications such as signage. In order for a vehicle to drive autonomously around these congested cities, and accurately interact with local traffic, buildings and consumer devices, it must have access to the most precise and up-to-date map data to help the car sense its environment and navigate without human input. TomTom aims to deliver this level of precision with its real-time maps.

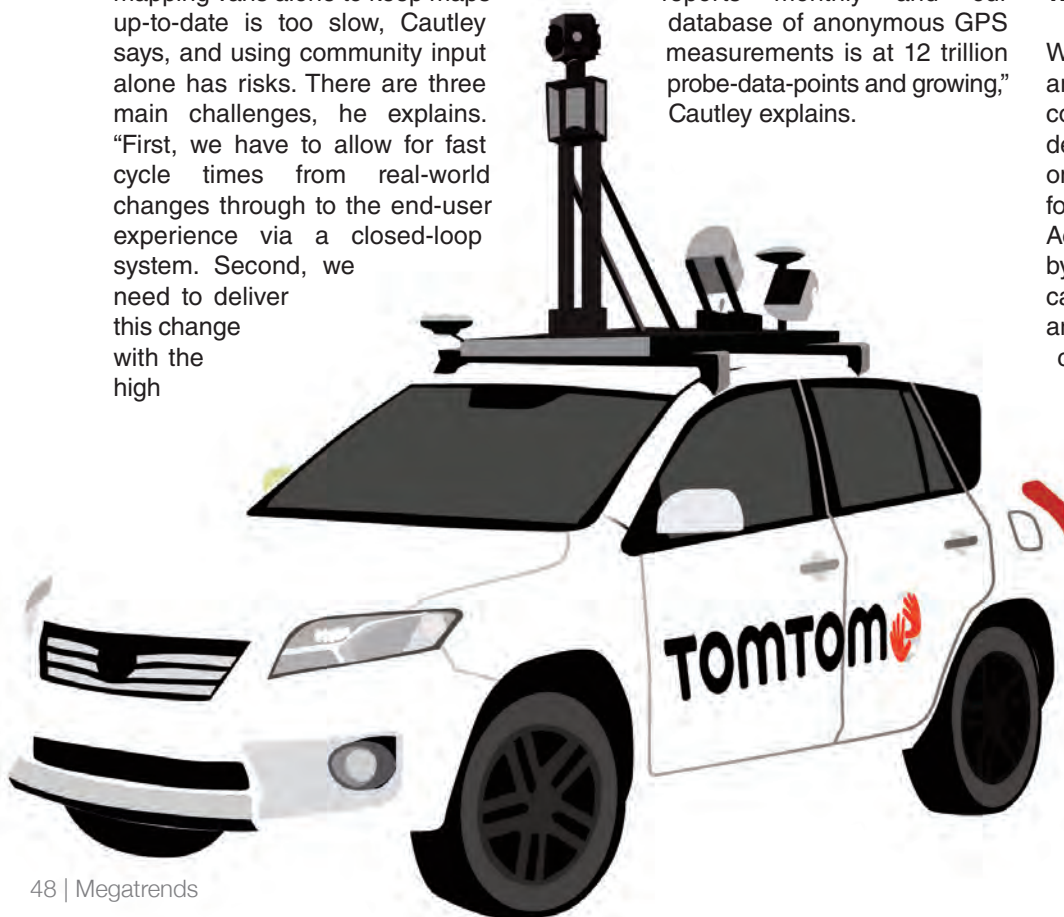

TOMTOM AUTOMOTIVE

Connected Navigation System

TomTom, the trusted partner for innovative and future-proof navigation technology for the global automotive industry.

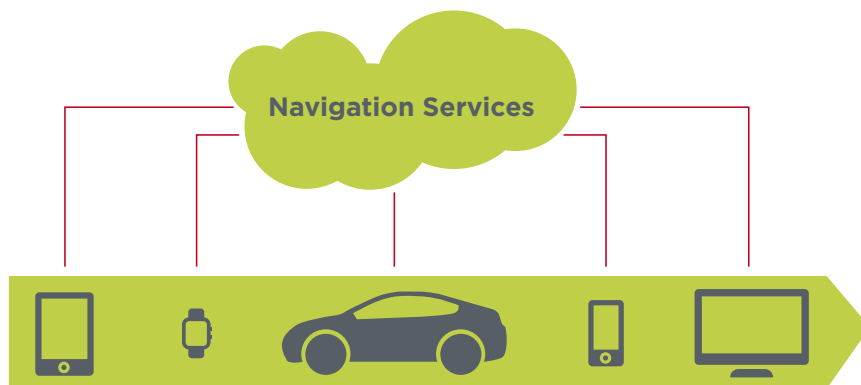

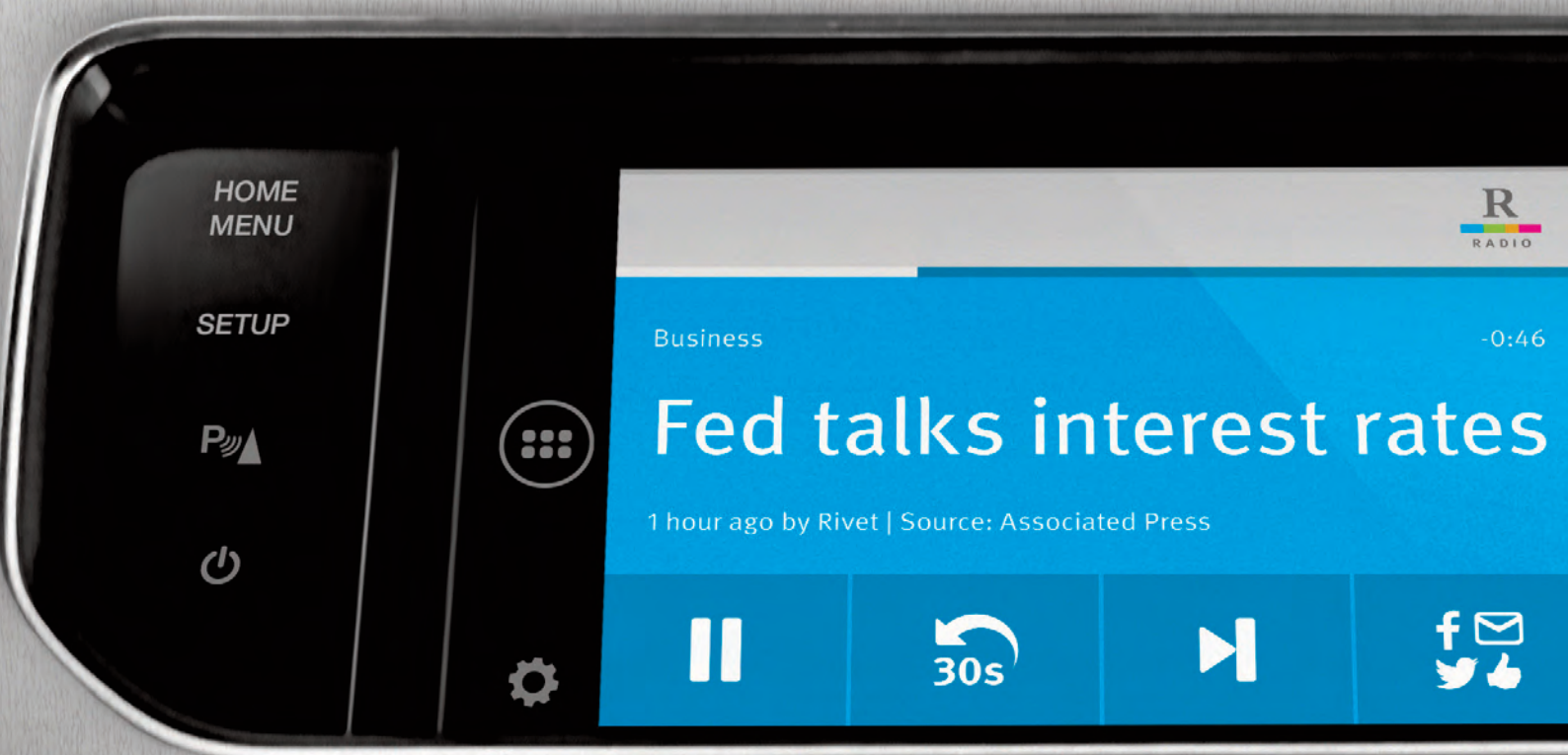

Over-the-air updates, of a different kind

Martin Kahl meets John MacLeod, Founder and Chief Executive of Rivet Radio

While vehicle manufacturers work tirelessly to develop an engine sound that best suits the brand and the performance expectations of a particular model, the sound most drivers really hear when they start their car – and for the majority of their journey – is probably the music or spoken word playing on their car audio system.

In-car audio has been through many stages of development, from simple AM/FM radio to music streamed from a Bluetooth-connected portable device, via 8-track, cassette, single and multi-disc CD players and even, for a short while, Minidisc. Currently, over-the-air

(OTA) broadcasting is being delivered by AM/FM (still), DAB/DAB+ (much of Europe, China, Australia), and satellite (North America).

The ubiquity of the smartphone has created an opportunity for another means of content delivery – smart audio, as developed by Rivet Radio. Established in 2012 by former Navteq EVP John MacLeod, Rivet was first launched on iOS one year later, and can now also be downloaded by Android and Amazon Fire users.

The aim of Rivet is to deliver interactive, on-demand, location-based audio content, MacLeod explains to

Megatrends. The content in this case is spoken word content – news, current affairs, sport – in fact, any spoken word selected by the user. The automotive industry is buzzing with discussions about the possibilities of over-the-air software updates for ECUs. What Rivet offers is effectively an OTA update for the driver, keeping them informed and up-to-date while on the move.

There's nothing new about broadcasting spoken word-only content, but Rivet has been developed specifically to keep users listening, wherever they are – at home, on foot or in the car. And the way its services are delivered means it has been



John MacLeod

radio model has moved to cable and then to Internet delivery of content. The irony is that audio, which was the first of the modern media, is the last to move to the Internet. Audio is highly engaging, because whatever you're doing, the audio is talking to you, it's inside your head. So for us, helping deliver compelling personalised audio content while you're on the go is a huge opportunity. And I think what we've done is a lot closer to how we're all going to be consuming audio in the next five to ten years."

Rivet enables users to decide what categories they do and don't want to listen to; users can pause and play, skip to the next story or back to the previous one. If a phone call comes in, the story pauses and picks up after the call is over. "Once you consume audio where you have control and power over it, you don't want to go back to just being pushed stuff that you may not want to listen to, and where your only choice is to change channels."

While AM/FM radio is predominantly advertising-funded, and satellite is largely subscription-based, Rivet Radio supports advertising, subscription and licencing models. Of particular interest to automotive OEMs is the embedded approach, suggests MacLeod. "If it is an API embedded integration where a system vendor or an OEM is writing their own software and interfacing to our content, then we would support either an advertising model, if we're able to send and track ads through it, or a licence model, where we would basically get a licence for our content." Rivet has been developed in this way, explains MacLeod, because industry, particularly the car industry, wants the

option of having more control over what content comes in and how it's consumed. "We've created, through our Cloud access, the ability for a car company to come in and grab our content and integrate it into their embedded experience."

As far as Rivet is concerned, audio is metadata; once tagged and categorised, it can be personalised and targeted as appropriate by Rivet's customers and users. "We have a very rigorous data format, with rules and rights surrounding what we produce ourselves and what we source from partners or from the community. The key idea is that once it's created, the metadata allows consumers, or car companies, or businesses to say they want a certain type of content playing on their device in their service."

Being online means Rivet potentially has global reach. Does MacLeod plan to take the location-based service beyond the US? "The OEMs are looking for global solutions for their car platforms, and we see ourselves as a global solution," he responds. "The Internet is global and the Cloud creates unlimited potential for content. Taking the lessons and the knowhow that we've assembled on producing and sourcing, which predominantly today is US news and information, we see that moving to international content coverage, and multiple language content. It really then becomes a content sourcing opportunity for us," says MacLeod. "That may be a little way off" he concedes, adding that from a technology and architecture perspective, "it's all in place today. It's really just about us growing and scaling our business to other content and other languages."

developed with the connected car in mind. "We have designed our business and our apps, our applications and our services, to fully take advantage of the connected car," says MacLeod.

"We see Rivet as a smart audio solution, enabling people to consume content on any device or through any kind of mobile application, or even embedded application. We have integrated our app experience into the Jaguar Land Rover platform with Bosch, and that's in the market today. And we've created an automotive API that allows system vendors and car companies to directly access our content through the Cloud, and then play it on their own software and embedded experiences in the car - and we're working with a couple of car companies to do that."

It's all about on-demand content, continues MacLeod. "The old TV and

When it comes to the connected car, it's all about "enablement"

...says Marques McCammon, Senior Director, Automotive Product Management at Wind River.

By **Rachel Boagey**

The automotive industry is undergoing a period of great disruptive change. The influx of electronics into the car presents a major challenge for OEMs, who ultimately need to partner up with companies that will enable them to aid the development of their in-car connectivity.

Wind River describes its role in the automotive industry as an enabler of software technologies, integration expertise, and lifecycle services, combined with in-depth industry experience and a rich partner ecosystem.

"The fundamental role of Wind River in the automotive environment is to provide enablement," explains Marques McCammon, Senior Director, Automotive Product Management at Wind River. "We analyse different levels in the value stream of the industry and specifically in the connected car and enable the end value that OEMs want to offer to the customer. If the objective of the OEM is to create higher levels of connectivity with web and web-related resources, we will enable them to develop and integrate this software as quickly, rapidly, cost effectively and robustly as possible."

Increased connectivity, increased risk

A growing trend in the market is the increased desire for the consumer to have a higher level of connectivity and advanced features, says McCammon. At the same time, there is an apparent unwillingness to pay for it. "The combination of those two things creates a pressure of cost and timing on the OEMs and their supply base. Mobile devices iterate quickly but cars

don't, so OEMs have to be prudent in the way they make investments as they aren't necessarily getting their costs covered," he explains. "We align our product strategy to help OEMs minimise upfront investment and maximise connectivity of the OEM software offering."

The company has been involved in secure operating systems since the beginning, says McCammon, and certifiable software systems are its primary software product. "That is the foundation of what we bring into the automotive space. A secure operating environment is our bread and butter."

Working together

The company also considers open source for the connected car as vital for its development. "We are one of the founding members of the GENIVI Alliance, so we are very well embedded in the foundation and structure of the open source connected vehicle." It also partners with Intel and the Linux Foundation in the Yocto Project, an open source collaboration project providing templates, tools and methods to help developers create embedded Linux-based systems.

"I think open source is critically important for automotive," McCammon continues, noting that the benefits allow for various elements of the connected systems in the car to be verified to ensure they have proper operability when they reach the automotive environment. "Open source also provides an opportunity to leverage software in a way that should provide speed and cost efficiency. The challenge is making sure there is sufficient robustness in open source to meet the needs of

automotive consumers, who are quite critical and not very forgiving." Indeed, says McCammon, in-vehicle infotainment (IVI) was one of the major detractors to some OEMs' quality ratings last year; companies need to be robust in their delivery, he says, but take advantage of the speed and flexibility of open source. "That is one of our unique value propositions," he says. "We have the ability to provide the bridge between what is traditional proprietary software and open source."

Wind River works with many automotive OEMs and Tier 1s, including more than 70 different names in the automotive space in 2014. "We help with anything from just providing the software platform to helping to architect software implementation, making us an automotive solutions group, not just a software or services group."

In the future, McCammon expects connectivity in the car to become ubiquitous, with everyone enjoying some base-level connectivity. "The car will be an extension of their everyday life, and connectivity will translate from home to the vehicle." To support the rapid acceleration of automotive software development, Wind River will build a basic framework "that is by design more stable so that new innovations can sit on top of it without providing risks to the overall vehicle," explains McCammon. He also predicts a more open community of people adding value into what can be done in a car. "This will be similar in fashion to the way the app world has developed for mobile devices. The aftermarket will take on a software element, causing a revolution in the automotive space."



GENIVI® How the GENIVI Alliance Works

The GENIVI Alliance is an automotive and consumer electronics industry association that drives collaboration among vehicle manufacturers and suppliers, to build open source infrastructure for in-vehicle infotainment (IVI) systems. IVI is a rapidly changing and expanding field within the automotive industry. It covers many types of vehicle infotainment applications including music, news and multimedia, navigation and location services, telephony, internet services and more. The alliance aims to align requirements, deliver reference implementations, offer compliance programs, and foster a vibrant open-source IVI community.

The majority of GENIVI's work is conducted through the technical and marketing teams and groups. There are currently six topical "expert groups" – Automotive, CE Connectivity, Location-based Services, Media and Graphics, Networking, and System Infrastructure. The EGs establish and prioritize the technical requirements, identify and enhance components that implement those requirements, and together develop the GENIVI Compliance Statement. In Asia, regional expert groups also develop specific requirements unique to their locations. All of these requirements are collected, reviewed and integrated by the System Architecture Team, resulting in a comprehensive compliance specification.

The Program Management Office develops and monitors the technical working plan resulting in a regular, six-month release cadence. The Baseline Integration Team provides a continuous build environment where EGs and members can test their developed software against a number of GENIVI compliant Linux distributions.

The GENIVI compliance program is a key deliverable of the alliance, providing the set of specifications for GENIVI member companies to measure their products and services. Those that meet the specifications may be registered as GENIVI compliant and listed on the GENIVI website. Compliant platforms consist of Linux-based core services, middleware, and open application layer interfaces. These are the essential but non-differentiating core elements of the overall IVI solution set.

Automobile manufacturers and their suppliers use these compliant platforms as their common underlying framework and add to it their differentiated products and services (the consumer-facing applications and interfaces). GENIVI is identifying these common automotive infotainment industry requirements to establish an open and robust baseline from which to develop products for the common good of the ecosystem.

The GENIVI Alliance is open for membership to all organizations engaged in the automotive, consumer electronics, communications, software, application development and related industries that are invested in the success of IVI systems and related products and services.

OEMs



First Tiers



OSV, Middleware, Hardware, and Services Suppliers



Silicon



Enabling choice, the GENIVI way

*Megatrends talks to the GENIVI Alliance about its Android Auto interface and the news of Daimler's decision to become a member. By **Martin Kahl***

In January 2015, to coincide with International CES, the GENIVI Alliance made a series of key announcements, including the news that GENIVI will fund a project to deliver an open interface to Android Auto. It also confirmed that in the first quarter of 2015, it will publish its GENIVI Development Platform, and that Daimler has joined the GENIVI Alliance, taking the number of OEM members to 13; established in 2009, the organisation now has over 160 members.

At the annual GENIVI Showcase, a networking event held in Las Vegas at the same time as CES, *Megatrends* sat down to discuss these developments with Kyle Walworth, John Lehmann and Steve Crumb. Walworth is VP Automotive Solutions and Strategy at Symphony Teleca and GENIVI Secretary and Treasurer; Lehman works at Jaguar Land Rover's

Open Software Technology Centre as Infotainment Strategist, and Crumb is the Executive Director of the GENIVI Alliance.

How does the GENIVI Alliance's funding and development of an open source interface for Android Auto fit with the GENIVI Alliance's strategy, and ensure that GENIVI members and the Open Automotive Alliance (OAA) - announced at CES 2014 - are all happy with the way things move forward?

Kyle Walworth: The GENIVI Alliance focuses on middleware for all infotainment features, including smartphone interfaces. Our SmartDeviceLink was Ford's, but is now maintained by Ford and hosted by GENIVI. We're very happy to integrate, and to create this open-source interface into Android Auto as it's a feature that everybody wants for their

smartphone, to work seamlessly and drive their system. I must emphasise what this is not: Google has not come out and said it will create a full OS top to bottom. Android Auto is an interface of the phone. It does touch into car communications, but it's all about using what's on your smartphone. It's generated in your smartphone, in your vehicle, in your vehicle screen.

Steve Crumb: Our strategy is to enable choice. Our architecture is intended to be a pick 'n mix architecture. There are mandatory elements of our architecture where we think it doesn't matter because it's a commodity and everybody is just going to pick whatever is available, and it just has to run. And there are other parts of our architecture where there are so many different commercially available options that we, as a not-for-profit organisation, are not going to tell OEMs what to pick. They're going to choose



what they want. If an organisation wants Android Auto and Car Play and SmartDeviceLink, we want to enable that in the most open way that we can. This project is an attempt to build this open layer, make it available to anybody, not just GENIVI members but any organisation with an interest in interfacing Android Auto, and make it available in an open way. That's really our goal – to provide open solutions that enable choice to the OEMs and the Tier 1s.

John Lehmann: That's been a goal since GENIVI was established. You enable choice by being open to working with anybody that the OEM community is going to want to work with for that functionality, and create an open-source way to address that.

KW: Open-sourcing the interface makes it easy for everybody to be able to integrate those technologies more quickly, and that's what we're all about. Look at GENIVI in general, and you'll see that we're in a series of very automotive-specific projects that help open-source be utilised for IVI. This is a perfect example.

You've confirmed plans to launch the GENIVI Development Platform in the first quarter of 2015. Can you please provide some more information about that Platform?

SC: We have not yet had a full stack reference platform. Software is not very tangible unless it's used. It's nice to have standard interfaces or individual components, but how do you make those tangible? You have to put them in the context of a full stack. So we're coming out with a technology demonstrator. It's intended to be given to solution architects and developers so that they can see how our interfaces work and how our individual components operate to do different things. And we hope that this demonstrator will help people understand the value of what technology is being produced by GENIVI and get more adoption, greater enhancement of those features, and more software.

KW: The demonstrator itself is an automotive board – a display and a software stack that runs some demonstration type applications that exercise the full GENIVI stack.

JL: It all comes down to making the work of GENIVI accessible and visible and, ideally, easy to get hold of and use. Things like the demonstrator are a step along the way. But it is going to be a continuing process and there's nothing keeping it from evolving, for GENIVI members initially, but later non-

members, universities, anybody. We want everybody developing their automotive applications on this technology, ideally.

Your other big news is the membership of Daimler, which brings another premium vehicle manufacturer into the group and takes the number of OEM members to 13. What do you see as the benefits both to Daimler and to GENIVI of Daimler joining?

SC: Daimler had known about GENIVI for a long time, and became convinced to join for a number of different reasons. One of those reasons was because their Tier 1s were in love with GENIVI, and they were providing GENIVI solutions. I think more and more OEMs out there are realising that GENIVI solutions are becoming increasingly accessible on the market and they feel they too should be part of it.

KW: Look at the Linux movement and the gravitation towards GENIVI of those companies who were interested in Linux. You have some OEMs that maybe didn't officially hit GENIVI compliance but have numerous GENIVI components inside. And that was planned by the OEM. The majority of all our Linux projects have membership here in GENIVI, or are gravitating in, and I think Daimler joining GENIVI is fantastic for the Linux movement and the GENIVI ecosystem because it's one more stamp for the Linux movement in automotive.



Daimler's decision to join the GENIVI Alliance takes the number of OEM members to 13



Bigger trailers for greater efficiency

*Dick Giromini, President and Chief Executive of Wabash National, tells **David Isaiah** about the role of trailer design in improving truck efficiency*

Freight transportation demand in the US is expected to exceed 25 billion tonnes in 2040, a figure which considers all modes of freight transportation, including road, rail, waterways and air. Of the different modes of transportation, trucking is expected to see particular growth, largely at the expense of rail and water.

In the US alone, freight transportation by road produces in excess of 1.6 billion tonnes of carbon dioxide emitted annually. This, then, translates into around 6% of total worldwide greenhouse gas emissions. Given these figures, emissions reductions in this segment will play a significant role in combatting global warming, while boosting profits for the fleets involved.

According to a study conducted by the North American Council for Freight Efficiency (NACFE), a US non-profit organisation working to double the

freight efficiency of North American goods movement, fuel costs faced by the tractor-trailer industry have been swiftly and steadily increasing over the past decade, rising to US\$0.64 per mile. As a result, fleets have been driven to include freight efficiency in their strategies.

Consider this: fuel usually accounts for a large, and often the largest, operating cost for fleets, even more than the costs incurred by a fleet for the driver. Despite this, there is, in general, a limited adoption of fuel saving technologies, both in North America and in Europe. Some of the factors that lead to a slow adoption of such technologies include the cost of fuel itself, the cost of technology, and capital restrictions at fleets.

According to Erik Jonnaert, Secretary General of the European Automobile Manufacturers' Association (ACEA), the

diversity of the commercial vehicle fleet affects the discussions about how to improve vehicle efficiency and safety. The incentives for improving fuel efficiency, for example, are far clearer than in the case of the passenger car market. Commercial vehicle operators spend around a third of their vehicle operating cost on fuel alone, so even slight savings can have vast impacts on the bottom line.

Asked about NACFE's target of doubling freight efficiency in North America, Dick Giromini, Wabash National President and Chief Executive, said he believes it to be an aggressive, but achievable goal, requiring a collaborative effort between truck and trailer manufacturers. He believes that with a combination of fuel saving technologies and improved aerodynamics, up to 10% fuel economy improvements can be derived from truck trailers.



“However, fuel consumption is only one part of the freight efficiency equation. There are opportunities throughout the supply chain. We’re already seeing an increase in freight density as electronics and other products have become smaller, along with efforts to optimise packaging. Consumer goods companies are eliminating excess air space in the design of their packaging, which increases density and the effective volume of freight per load,” Giromini told *Megatrends*.

Europe’s freight movers have also been making strides in improving freight efficiency. In 2008, ACEA’s commercial vehicle manufacturers committed to an agenda called ‘Vision 20-20’ which aims to reduce the fuel consumption of commercial vehicles by 20% by the year 2020 compared to 2005. This is equivalent to an annual 1.3% improvement in fuel economy with commensurate reductions in carbon dioxide emissions.

Clearly, fleets are continually evaluating their operations in order to find more ways to improve efficiency – be it lane or route optimisation, reduction in empty miles, freight loading/unloading,

speed limiters and other measures. According to Giromini, efficiency is being driven by new technology and design innovation. As a result, many fleets are testing and deploying the latest fuel efficiency technologies, on both tractor and trailer.

According to the NACFE study, there are around 1.5 million tractor trailers operating in the US. Together, these account for the consumption of around 26 billion gallons of diesel. To put things into perspective, every 1% reduction in fuel use translates into 260 million gallons of diesel saved, which, annually, would be worth around US\$1bn.

Trailers play a significant role in improving freight efficiency, especially as it relates to fuel economy. The more aerodynamic the trailer design, the greater the reduction in fuel consumption. However, fuel efficiency through aerodynamics cannot come at the cost of cargo capacity.

Just how great are the fuel savings that technology-intensive trailers can deliver? If a fleet uses low rolling resistance tyres, combined with features to improve a trailer’s aerodynamic efficiency, such as side skirts and a tail device, fuel savings in the range of 8-10% can be gained, according to Wabash National. This is of course at highway speeds, and depends on the type of trailer used, the length of haul and freight operation.

“Trailers are regulated by overall length, width and height. Given these boundary parameters, we’ve essentially taken cube capacity to its limits with current technology. However, opportunities remain to take even more weight out of the trailer, thereby increasing effective cargo mass capacity so more freight can be hauled,” said Giromini.

There are three main ways to improve a trailer’s efficiency: reduce aerodynamic drag, improve rolling resistance and reduce the weight of the trailer. With regard to aerodynamics, the three main areas where drag occurs are the tractor-trailer gap, the side and underbody of the trailer, and the rear end of the trailer. According to a white paper on trailer technologies by the International Council on Clean Transportation (ICCT), efficiency can also be improved through the use of

alternative materials such as composites and aluminium, in wheels and structural supports.

Wabash National, too, has been working to advance the science of trailer design, aimed at more effective, efficient and safer operation. The company’s current direction of development includes weight optimisation through advanced materials and the development of new aerodynamic devices and designs.

Regulations play a significant role in improving freight efficiency as well, be it tractor or trailer. In mid-2014, after the EU’s Transport Council agreed on the revised directive on the weights and dimensions of trucks, ACEA’s Jonnaert said that this provided an opportunity to reduce CO2 emissions more efficiently from heavy-duty vehicles.

“Industry should have the flexibility to make use of revised rules to deliver even cleaner and more efficient trucks in the most cost-effective manner. Allowing an extension of the current maximum length of vehicles and vehicle combinations, while complying with legal requirements, will enable the industry to incorporate both existing and future fuel-efficiency innovations into their designs,” he said at the time.

Similarly, from the trailer standpoint, Giromini feels that to make even more significant improvements in freight efficiency, one would have to evaluate existing equipment regulations, such as trailer length and weight restrictions. For example, fleets in the US are currently pushing for the approval of 33-foot double trailers instead of the existing 28-foot dimension.

If passed, less-than-truckload carriers would see an increase in their freight capacity by 18% per trailer without putting additional trucks on the highways, according to Giromini, who summed up the discussion with compelling argument: “This would not require changing any weight limits, nor infrastructure, but would have a significant effect on capacity. Said another way, at current demand levels a fleet could eliminate one tractor for every ten 33-foot combos in service. This would not only decrease fuel consumption and related greenhouse gas emissions, it would reduce road congestion and potentially enhance highway safety.”



Fleet managers - lap up the fuel-good feeling!

Low fuel prices are great for fleets. But account for every drop - it won't be this cheap forever, writes James Hookham, Managing Director – Membership & Policy at the UK's Freight Transport Association

The sustained drop in fuel prices over the past nine months (to February 2015) has been welcomed by consumers, businesses and economists the world over. Even politicians have been getting in on the act, eager to associate themselves with voters getting the feel-good feeling that comes from realising it costs about £10 / US\$15 / €14 less to fill their car than it did this time last year.

For most fleet managers, the fall in fuel prices is welcome as their budgeted cost line will show a healthy positive variance for the year. Hauliers with open book contracts or fuel escalation clauses will be sharing this saving with their customers eventually, but the reduction by a third of the biggest overhead in a fleet after labour can only be seen as a positive development.

Except, that is, for those who signed a contract to guarantee the price of their fuel at prevailing rates in the first half of 2014. In which case, they may well be contractually tied to paying fuel prices possibly as much as a third more than their competitors! The hedging of fuel prices is effectively a bet against the market. It is a precarious business needing dedicated and knowledgeable people well versed in commodity market trading techniques. This is only worth it if buying very large volumes of fuel for delivery across wide geographic areas for several thousand vehicles. The only smaller fleets doing this are those that are part of a high intensity energy utilising manufacturing business, where fuel for the vehicle fleet is being bought as part of much bigger trades for the main production processes.

Are US\$50 oil prices a megatrend, likely to last for ten years? Unlikely – so enjoy it while it lasts. The price fall has already bottomed out, and some smart money is now betting that oil prices will start to rise. The trouble with all these predictions is that the market is responding to far from normal events, so there is no reliable precedent to follow.

The two main reasons for the drop in prices in 2014 were the decision by Middle East producers (OPEC) to keep production levels high despite a drop off in demand due to a slow-down in the world economy and the rapid substitution of crude oil products with shale gas, particularly in the USA. Both factors created an excess of supply over demand that would normally be countered by restricting production, keeping the price high. It was OPEC's



decision not to do this in the autumn of 2014 that turned the price dip into a slump and has so unnerved smaller exporting nations and the oil industry in general. None of these factors are permanent, and could be reversed as quickly as they emerged. Market observers are expecting prices to recover to about US\$70 by the end of 2015, but to remain under US\$100 for the medium term.

The real megatrends underlying the price of crude oil, however, have not fundamentally changed. New oil discoveries are proving just as difficult to reach and expensive to recover as they were - think Alaska, Arctic Ocean, Western North Sea; and the more geologically accessible supplies are still located in some of the most politically unstable parts of the world, such as Iraq, Iran, Syria, North Africa, Russia and Nigeria. The depths of the geological formations in which new reserves are being found require new and very expensive technology to bring them to surface. Most of these reserves require a price of at least US\$70 a barrel to make them economically recoverable, and many were barely profitable at 2014 prices. Geologists say there is enough oil in the ground to meet all foreseeable demand. What is in doubt is whether it can be recovered at a price people are prepared to pay.

On top of this is the possibility of the introduction of carbon taxes by governments to discourage the use of hydrocarbon fuels to meet greenhouse gas emission targets, an issue strangely silent in the current cheap oil debate.

So, how should fleet managers responsible for fuel procurement approach this critical cost line in their budget in the longer term? The key message is to make fuel management, from procurement to consumption, a key management priority and to see through the noise to understand the real market signals.

First, there is a presumption that a fall in oil price will immediately be reflected

in an equally big fall in the forecourt price. The two benchmark prices quoted in the press (Brent Crude and West Texas Intermediate) are in fact forward prices for deliveries of oil in three months' time. So gasoline and diesel selling on the forecourt today was in fact refined from oil bought at prices that prevailed up to six months ago, allowing for refining and distribution time. There will thus inevitably be a lag between plunging oil prices and the delivery of product refined at that price.

Second, understand that the refining and distribution of automotive fuels follows its own rules of supply and demand. Diesel is often blended from refined products that are also feedstocks for other processes and markets. Competing demand for these may well influence diesel prices independently of crude oil prices and on a regional basis.

Third, track the price at source and shop around for deals, just as for any other energy supply. One reassuring trend is that prices reported by members of the UK's Freight Transport Association for bulk delivery of diesel fuel in the UK show a close correlation to the main benchmark price quoted on the European market, allowing for delivery and handling costs. Much of the reported variability in fuel prices seems to be happening in the retail market downstream of bulk purchase, often influenced by the pricing strategies of major retailers. In the UK, those major retailers now own about half the fuel nozzles on the country's forecourts.

The message, then, is clear: where practicable, source bulk supplies at wholesale prices, either direct to your own storage or into a shared bunker scheme. Stay on top of developments with a good price index; keep up to date with a good market monitor; and take the purchasing of fuel every bit as seriously as its usage by drivers and consumption in vehicles. Account for every drop - it won't be this cheap forever!

Interview: Jim Arthurs, Executive Vice President of Heavy-Duty Systems, Westport

Jim Arthurs, Executive Vice President of Heavy-Duty Systems at Westport, gives an update on the company's strategy and highlights the current megatrends affecting the heavy-duty segment

Jim Arthurs is the Executive Vice President of Heavy-Duty (HD) Systems at global developer of natural gas (NG) technologies for the transportation sector, Westport. He is responsible for the company's innovative development in large engine technologies, and oversees a number of collaborative projects between partners such as Volvo and Delphi. As well as his role at Westport, Arthurs is the Chairman of Cummins Westport, and also holds a position on the Board of Directors. In an interview with Megatrends, Arthurs outlined the current megatrends that are affecting the heavy-duty segment.

What technology is Westport focusing on at the moment?

In the heavy duty space, the main powertrain technology that we are trying to industrialise right now is high-pressure direct-injection (HPDI). It differs from the traditional spark-ignited engine in that, instead of using a sparkplug to light the NG, we use a little bit of diesel.

HPDI technology provides a number of benefits compared to spark-ignited technology. The engine runs more like a conventional diesel engine should run – it has a true diesel cycle compression ignition. It has the same horsepower torque and fuel economy as the equivalent diesel engine, but is more efficient. However, it is a little more costly as it is a much more complex technology. Therefore, it tends to fit better in the high fuel consumption applications.



Historically, we had a Westport 15-litre engine using this technology that was derived from the Cummins ISX15 platform. Over the last few years, we have shifted and now we are working directly with engine OEMs. We have been working with Volvo, for example, to develop a version of its 13-litre engine that uses this Westport technology. There are also a number of other OEMs that we are working with who wish to utilise our HPDI technology.

Has the verticalisation trend affected which companies Westport can and cannot deal with?

We work with a number of different industry players in different stages. As well as working with integrated OEMs

like Volvo and Ford, we also have our joint ventures with Cummins and Weichai – both of whom are independent engine suppliers. What is more, we do a fair bit of aftermarket work, more in our Applied Technologies Group, which is a components business.

From our perspective, we are not going to influence how the verticalisation trend plays out. Therefore, our strategy is to work with all customers that may benefit from our solutions.

Has verticalisation affected Westport's approach to the global market?

In Europe, the heavy-duty market has always been fairly verticalised. In the north of the US, on the other hand, suppliers have a big share of the marketplace – OEMs using their in-house engines and transmissions hold approximately 60% of the business, whilst Cummins has acquired roughly 40%.



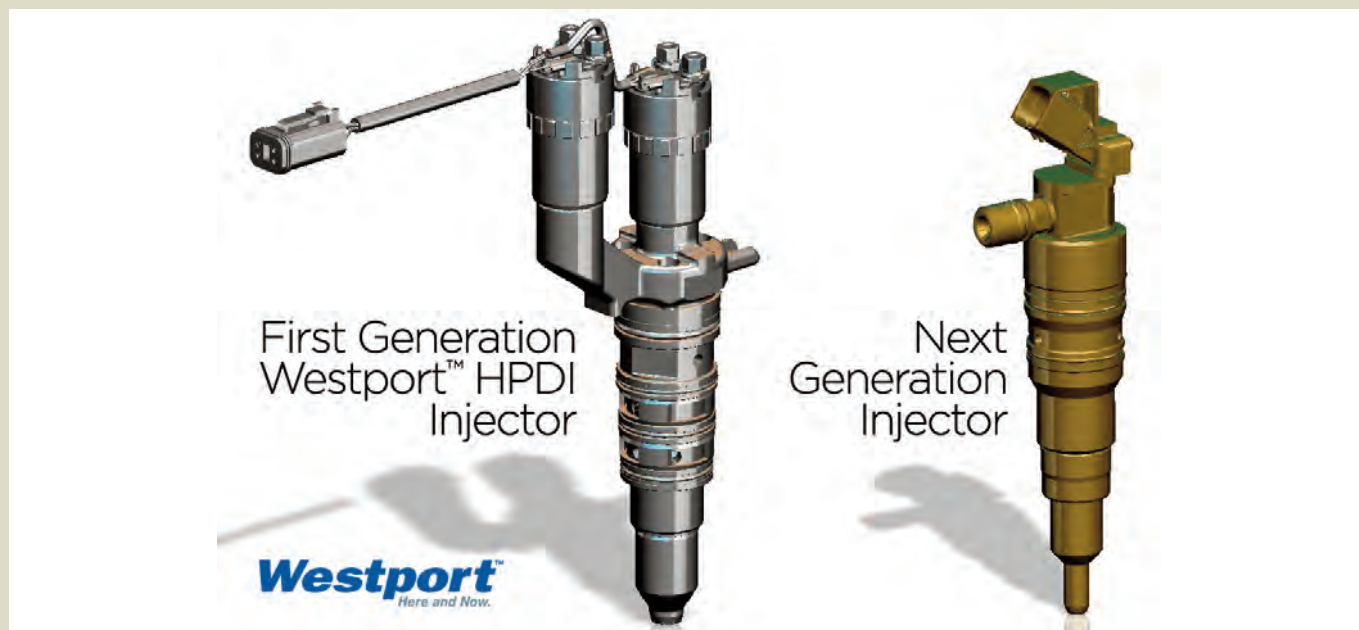

The interesting thing has been the level of competitiveness. Integrated OEMs look at the ability to optimise fuel economy, for example, by having a relationship between the engine and the transmission, as well as other aspects of the vehicle. Yet, Cummins and Eaton have come together and essentially achieved the same thing.

I think we will witness much more competition and innovation between the two camps all across the world. At the end of the day, it is good for the industry. How it will play out and what the market share will be five years from now is impossible to predict.

Have the falling diesel and gasoline prices affected Westport's HD Systems development?

In the short-term, low oil and fuel prices are certainly not a positive trend for Westport. As they continue to fall, the commercial vehicle (CV) segment is renewing its investment in diesel trucks. Fleet operators are in their comfort zones, and are reluctant to even think about innovative technology.

So Westport has seen a little bit of an ebb. However, everybody who has studied fuel prices knows that this

unprecedented decline we have seen of 55% in the price of a barrel of oil is probably a blip on the radar in the grand scheme of things. What we are seeing at the moment is an interesting supply/demand effect. Saudi Arabia has changed its strategy, allowing the prices to fall to clear out an excess supply of oil. But, suppliers of oil and even governments need much higher prices than where they currently lie in order to balance their budgets. This goes for the US and Europe. Most of the major suppliers will not be making any money at US\$40 or US\$50 a barrel.

Will higher diesel and gasoline prices mean renewed interest in NG?

At some point, the pendulum has to go the other way and prices will recover to some level. When that happens, we will be ready. There is a lot more discussion and interest in alternative fuel when diesel and gasoline prices are high and rising.

We are still having lots of conversations with people that are looking at long term – whether it is three years, five years, ten years from now – who want to start or continue their investment in NG. In the world of transportation in general, the underlying trends are still positive for NG. The cost of NG is still about one third that of both diesel and gasoline, even when a barrel of oil is at US\$50. So, with gasoline and diesel at a commodity level, NG is still far cheaper.

A version of this article first appeared on AutomotiveWorld.com

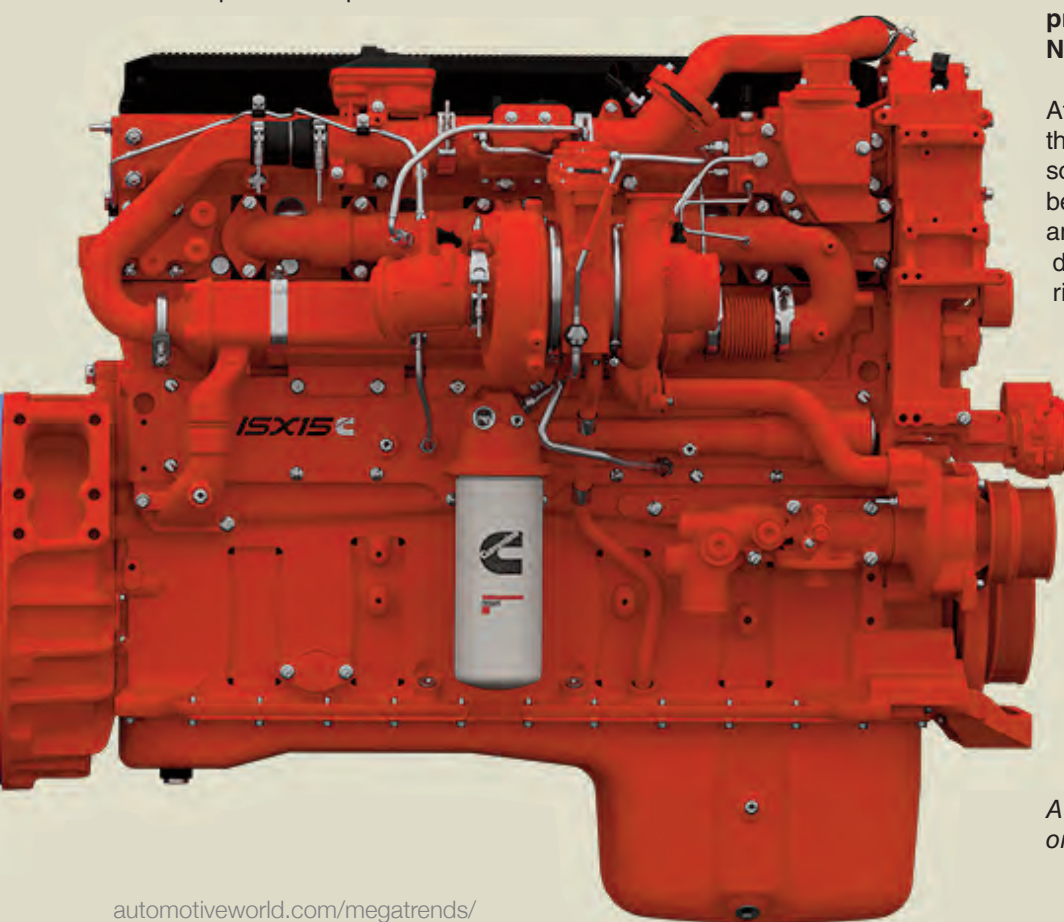



when
cars
talk

Cars are rolling gold mines of information, gathering data about the driver, the driving environment and of course—the car itself—as well as any devices connected to it. Automotive companies can use this data to provide a safer driving experience, improve customer service and enhance vehicle quality.

And the benefits associated with real-time analysis of data collected from vehicles extend beyond just the automotive industry. Insurance companies can more accurately assess risky driver behavior, enhance the claims process and identify fraudulent claims. Fleet operators can use vehicle data to improve the efficiency and safety of their operators, and retailers can improve the timeliness and accuracy of product promotions.

With IBM Watson Foundations Big Data & Analytics technology, automakers can now analyze huge volumes of vehicle data at speeds that allow cars to “talk” to each other through the cloud. This vehicle-to-vehicle communication makes it possible for drivers to receive real-time alerts about nearby hazardous road conditions or looming equipment failures. Watson Foundations can also provide a more enriched driving experience through application or entertainment offerings customized just for them, and delivered through their vehicle’s infotainment system or a connected device.

To learn more, visit ibm.com/software/data/bigdata/industry-auto.html

Big Data & Analytics



PHEVs - “a major step towards zero-emissions driving”

Michael Nash looks at some of the key PHEV launches at 2015's CES and NAIAS

The start of 2015 saw a wide variety of innovative technologies showcased at International CES and the North American International Auto Show (NAIAS). Although CES has now firmly booked its slot as a must-attend automotive show, the Las Vegas and Detroit events have very different agendas: CES highlights vehicle technology, while NAIAS takes the more traditional approach, focusing on new model launches. Despite their differences, there were clear signs at both shows that hybrid electric vehicles (HEVs) and plug-in hybrids (PHEVs) are high on the agenda.

With a keynote from its chief executive, and a concept car that even featured in the mainstream media, Daimler made CES its own. The F 015 Concept presented the company's vision for the future of autonomous driving; it also showed where the company sees

powertrain technology heading: the F 015 uses an electric hybrid system with a combined range of 1,100km (685 miles), including 200km of battery-powered driving and around 900km on the electricity from the fuel cell.

A week later, the F 015 was on the Mercedes-Benz stand at NAIAS, where

the OEM began its launch of a number of innovative powertrains across different models, showing a clear commitment to PHEVs. According to Thomas Weber, Member of the Board of Management of Daimler AG, the company intends to offer “no less than ten models with plug-in hybrid drive – and not just for our SUVs, but our core models, too.”



Dieter Zetsche gives a keynote address at CES 2015





Acura NSX and powertrain seen from above

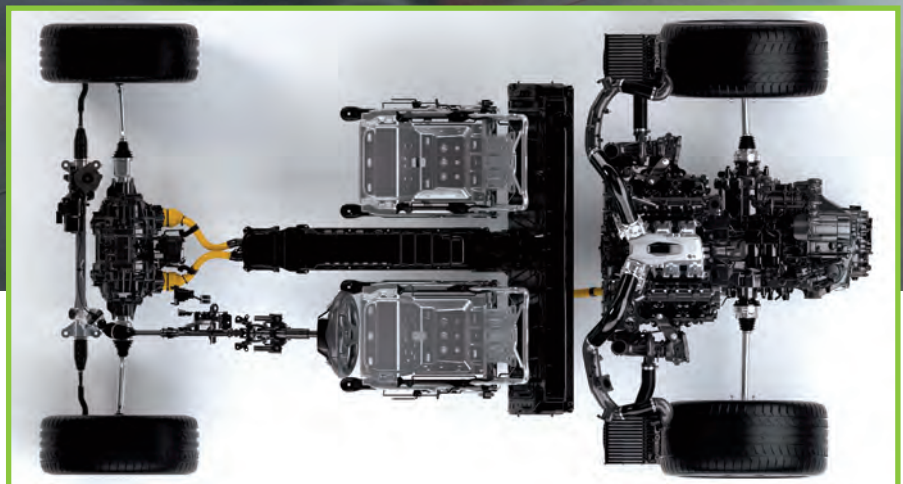

As part of its plan to produce the ten PHEVs by 2017, Mercedes-Benz revealed a brand new C 350 HEV at NAIAS, which uses a 2.0-litre four-cylinder gasoline engine mated to an electric motor. And it's a sign of things to come for the OEM, Weber stated: "For us, the plug-in hybrid will mark a major step towards zero-emissions driving over the next ten years."

Volvo used NAIAS for the North American debut of the all-new XC90. The model utilises the OEM's new Scalable Product Architecture (SPA) technology, developed specifically to allow it to be equipped with a broad range of powertrains, including the D4 turbo diesel engine, and a new "Twin Engine, which combines a supercharged and turbocharged petrol engine with an electric motor."

The vast array of powertrains on offer comes from Volvo's mission to offer a range of solutions to meet the demands of various markets across the world. Michael Fleiss, Vice President of Powertrain at Volvo Cars, told us, "we have a very efficient base powertrain, and with that as a main platform, we can offer electrification when the customer wants it. We at Volvo believe that in the future there will be a bigger demand for the customer in the electrification area, but it will always be combined with a very efficient base engine."

Honda made a spectacular contribution to the HEV segment at NAIAS with the long-awaited, brand new Acura NSX, which boasts an all-wheel drive (AWD), V6 hybrid electric powertrain. Drivers won't be able to plug it in, though, restricting the number of electrically-driven miles the car can travel. A seven-speed, dual-clutch gearbox is present, and the same mid-engine layout from the previous NSX remains, as the OEM hopes to replicate and improve on performance and feel. Sales for the NSX are expected to start during 2015, but may not begin until the latter end of the year.



Volvo XC90

Finally, Hyundai launched its all-new Sonata PHEV. A 2.4-litre Atkinson Cycle Dual Over Head Camshaft (DOHC) 4-cylinder gasoline engine is accompanied by a 35kW electric motor. Mike O'Brien, Vice President of Corporate and Product Planning at Hyundai Motor America, told press that the OEM's innovation in battery technology enabled the Sonata to "travel up to 22 miles entirely on battery power – the best all-electric driving range of mid-sized cars."



Chevrolet Bolt and Volt (left)

density than the previous generation. GM claims the new Volt is around 12% more efficient and 45kg lighter than its predecessor. These innovative new powertrain developments will allow drivers to travel an average of 1,600km before needing to visit a fuelling station.

At Detroit, the new Volt sat alongside the OEM's new compact EV concept, the Bolt. With an all-electric range of 320km (200 miles), the Bolt was described by GM's Chief Executive Mary Barra as a "game-changing EV". It has been confirmed for production, and is slated to hit markets by 2017. For now, though, the importance of Chevrolet's new PHEV, the Volt, takes precedence.



The majority of eyes at CES 2015 looked to the future, as a number of OEMs decided to showcase various concept cars that are heavily connected to the point of autonomy. There were, however, a handful of OEMs and suppliers displaying new and innovative powertrain technology that focused on the here and now.

On Elektrobit's CES stand were two vehicles – the Volkswagen e-Golf and the Mercedes-Benz E400 Coupe, both of which feature Elektrobit software. While the Mercedes-Benz was there to showcase the strong relationship that Elektrobit has with the OEM particularly with regard to driver assistance technology, the e-Golf was present to highlight EB's electric car-related software. "In the e-Golf, the UI system is designed with our EB GUIDE toolset," explained Elektrobit's Walter Sullivan. "It's an HMI modelling development tool. Our navigation software is running in the infotainment system. And then our ECU software was used to implement the car's electric charging system."

GM used CES to provide a very brief glimpse of the 2016 Chevrolet Volt.

automotiveworld.com/megatrends/

Although it only made a short appearance at the show before its official unveiling at Detroit a week later, the highly anticipated Chevrolet Volt lapped up attention. The PHEV includes a 1.5-litre gasoline direct injection engine, accompanied by two electric motors. During operation, either or both can be used depending on driving conditions. The battery pack, provided by South Korea's LG Chem, is lighter and also has greater energy

Hyundai Sonata PHEV



Range anxiety: information delivery is key

Megatrends speaks to Walter Sullivan, Head of Innovation at Elektrobit Automotive's new Silicon Valley research lab, on the challenges of addressing 'range anxiety' in electric vehicles

By **Freddie Holmes**

Fuel light bingo - how many fuel stations can you drive past before the fear of running out of fuel kicks in? For drivers of electric vehicles (EVs), this is a riskier game – and a game they play far too frequently, whether they like it or not. Without the abundance of fuel stations to reassure them, confidence in making it to a charging station diminishes – hence the phrase 'range anxiety'.

Global EV charging station numbers are expected to soar from 135,000 in 2011 to 10.7 million by 2020, according to a report by IMS Research. Until then, drivers of EVs will need to continue planning their routes around known charging point availability.

Elektrobit (EB) software and hardware technology powers more than 75 million vehicles worldwide. Despite differences in propulsion, Walter Sullivan, who heads up the company's new facilities in Silicon Valley, believes that the electric car is not so different from its oil-burning cousin.

"It's interesting, because in many ways an electric vehicle isn't that different from a non-electric vehicle," he says. "It still needs a navigation system, it still needs an HMI, and the ECUs still need to communicate with each other, so in some ways it's similar to any car for us, but it has some unique challenges."

Painting a picture

Sullivan explains that the HMI in an EV needs to present information to ensure the driver is comfortable with the vehicle's ability to reach the destination, or if the charge is low, to find a charging station in time. "The navigation system that we build needs to calculate a route that is friendly to an EV and present the user with a visual boundary that illustrates how far the car can go," he says. This varies according to traffic conditions, road elevation and other factors, but because EVs and traditional internal combustion engine (ICE) cars share

similarities in the HMI, many of EB's products are also able to address EVs.

The VW e-Golf uses almost all of EB's product technologies, which the OEM adapted to suit its specific needs, explains Sullivan. "VW used our HMI tool for designing the interface in the vehicle itself, so they were able to customise it. They adapted the traditional infotainment unit that is used across the rest of the Golf range with some unique HMIs for the electric side. The navigation system and the ECU that manages the charging of that system is from an EB software stack. It's fairly unique, and a good example of how we can address e-mobility," he says.

Making charging accessible

EB's navigation system has an interface that can connect to an external data source, such as a charging station, and "will provide assurance to the driver that when they get to where they are going, they can charge it."



Daimler's car2go provides car sharing services in European and North American cities using smart fortwo cars as one-way point-to-point rentals. To make the driver aware of designated car2go parking spots, their locations are fed into Street Director – EB's navigation system – from an external server. Free spots appear in green and occupied spots in red.

Sullivan believes this can translate across to navigation systems used in EVs to show the location of available charging stations: "From an online service, we can get the available parking spaces for the smart cars and actually direct the driver to an available spot. We don't have that for charging stations yet, but it is easy to make that mental extension."

Face your fears...

Sullivan believes the industry can improve its ability to calculate routes in order to optimise battery usage in an EV, the key to the supply of information the driver receives. Information about the condition of the battery, how much charge is left and how far they can

expect to travel helps to alleviate range anxiety, he says: "The information being presented can help drivers make informed decisions about how they use that vehicle." Eventually, he hopes this will become "a non-issue" when battery technologies improve in future, "but for now, it's something we're trying to tackle."

A secondary problem that supplements range anxiety – and possibly exacerbates it – is the fact that EV drivers have to plan longer journeys more thoroughly to incorporate a route with charging stations along the way, or at least local to the end destination. This can be especially problematic in remote areas. Presenting this information to the driver does not eliminate the need to plan a journey, but Sullivan believes this will significantly help in reducing the uncertainty of a journey, and adds that this is not just a problem reserved for EV drivers. "Any time you have a finite resource at one end of your journey, that journey needs planning. We're producing the technology that's improving the efficiency of that process," he states.

Suppliers are developing smartphone applications (apps) that show the user how much charge the battery has left, and can estimate the time remaining to reach a state of full charge. While EB does not produce similar apps, Sullivan explains that its technology is the 'middle-man' in this scenario. In the case of the e-Golf – to the extent that the car itself is getting the charge level for the battery and sending it to the phone – "that comes through the module using our software that is managing the charge," he says. "But as far as the technology on the phone itself is concerned, that's down to the phone applications developed by everyone else. We have the software that supports these apps."

For Elektrobit – and electromobility on the whole – range anxiety is the primary barrier to EV adoption for consumers. The main contributor to this is not something EB can counter directly, but can address using HMI tools and intelligent navigation systems. As battery technology improves to meet a similar range available in conventionally-fuelled vehicles, the fear of losing charge is expected to dissipate.





Elektrobit

FUTURE OF SOFTWARE

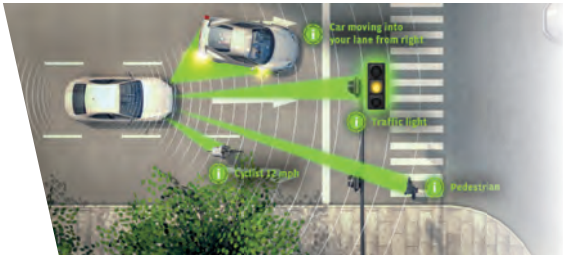

Paving the way for autonomous driving with smart software:

- ▶ Connectivity
- ▶ Mobility
- ▶ Safety and Security

Providing engineering services and software solutions for major auto makers around the globe.

**Elektrobit (EB) Automotive -
An Innovative Software Partner to the Automotive Industry**

▶ automotive.elektrobit.com ◀



Squeezing pennies from the BEV segment

A new Automotive World report asks whether OEMs can make a profit from battery EVs

Electric vehicles (EVs) will play a big role in the future of transportation. Despite continual improvements in internal combustion engines (ICEs), a form of electrification is considered to be crucial by many industry experts if OEMs are to hit future emissions and economy requirements. The question is, how can OEMs and powertrain developers make battery EVs (BEVs) a more lucrative segment?

Bargain batteries

Battery cost continues to be an issue for the BEV segment. However, industry experts have suggested that the price of batteries is coming down by as much as 25% per year. This is due to a number of reasons, the biggest of which is development.

Many companies have been developing innovative batteries in the hope of tackling the cost issue. Most recently, SolidEnergy announced that its new 'anode-less' battery provides double the amount of energy density than previous lithium-ion batteries, whilst being up to 80% cheaper.

However, like many other developers, SolidEnergy does not expect to bring the new battery to the market for at least another two years. Yet, as Founder and Chief Executive of SolidEnergy, Qichao Hu, points out, the threat of new and cheap batteries has been "enough to spur other companies into reducing the cost of their batteries."

Innovation and development aside, scalability is another factor that could

potentially help lower battery prices. According to Cosmin Laslau, Mobile Energy Analyst at Lux Research, production in "greater volumes" could help reduce the costs of batteries significantly. He details Tesla's Gigafactory as a model for this avenue. Laslau believes that it is unlikely OEMs will get to a price with which they are comfortable through this method. Batteries could, however, "get to a place where it's cheap enough to compete with some lower priced vehicles."



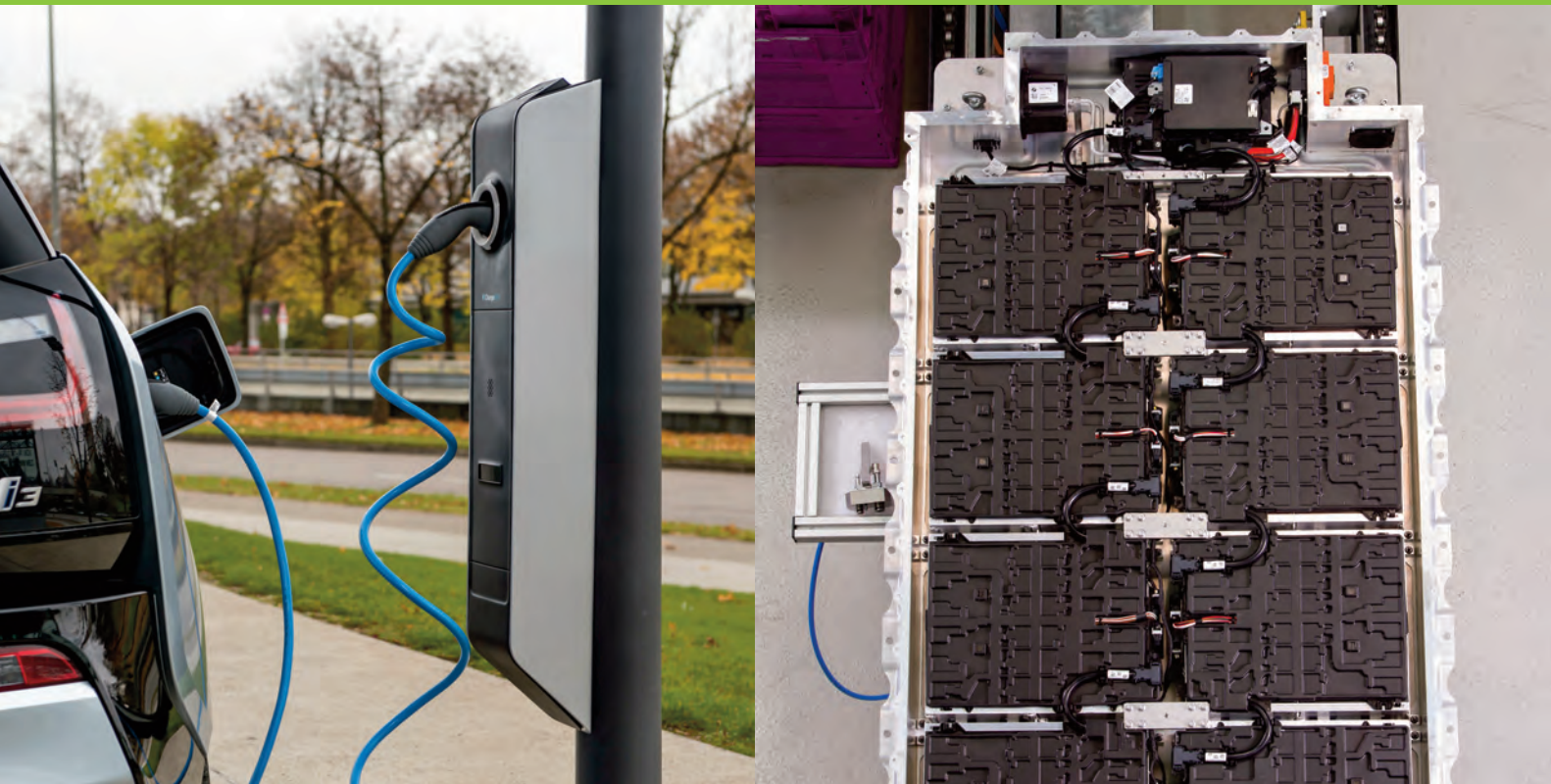

Cheaper models, bigger bonuses

Following on from the mass production of batteries, Tomoko Blech, a Representative of CHAdeMO Association Europe, a global distributor and developer of DC quick chargers, believes that high volume production of EVs themselves will improve the profitability of the segment. “EV production requires a great deal of capital investment,” he explains. “Cost reduction through high volume production” could therefore offer the most simple solution. “To achieve this, OEMs will need to bring to the market EVs that are attractive to a great many potential EV users,” says Blech.

Laslau recalls that traditionally, EVs have been expensive, and have often resided in luxury segments. However, there is an increasing number of OEMs looking to include cheaper EVs across a range of different segments.

“A great example is the BMW i3, against which Tesla is going to compete directly with its upcoming Model 3,” explains Laslau. “Both will be around the US\$35,000 – US\$40,000 price point. That’s still not cheap, but it is better than what Tesla has had so far.”

Through offering a greater range of EVs, Laslau believes that OEMs can broaden their market space. Not only will this promote the adoption of EVs to different groups of people, but it could also maximise the profits on offer for OEMs. This approach has

been utilised by BMW, as it has developed an entire range of EVs, from affordable to luxury. Manuel Sattig, BMW i Project Manager, explains that “the i3 and i8 are the book-ends. We’re looking at potentials in between, above and below. The mission is very clear: we will go on after i3 and i8. And our idea is to enlarge the BMW i family.”

Hand-in-hand

If the price of batteries is reduced, and OEMs target a broader audience, will the BEV segment become more lucrative? According to Gloria Esposito, Head of Projects at the Low Carbon Vehicle Partnership (LCVP), the two factors go hand in hand. Whilst sales have been much slower than expected, growth will be spurred by

both a greater option of BEVs and cheaper batteries.

If Esposito picks one factor that will help OEMs maximise their revenue on the BEV segment it would be through the reduction in battery price. She describes it as the “dominant factor influencing BEV price.” However, by 2020, there will be a “sharp decline in battery price” This, she believes, will directly equate to a rise in profitability for OEMs which produce BEVs. Furthermore, with positive sales growth forecasted for the foreseeable future, many industry experts believe that the BEV segment holds an enticing profit for OEMs

To read this report, go to <http://www.automotiveworld.com/research/can-battery-evs-ever-profitable/>



S for swap: Tesla says its battery swap technology can replace a Model S battery in less time than it takes to fill up with gasoline



Local sourcing – it's the new global sourcing

*Global sourcing strategies are giving way to local sourcing as OEMs seek to reduce the vulnerabilities and logistics costs associated with long supply chains, writes **Indraneel Bardhan** of EOS Intelligence*

Not long ago, the buzz term for the automotive world was global sourcing. OEMs aimed to standardise product offerings and pricing by producing in select emerging countries that offered low production costs. This rendered the supply chain long and complex, but equally justified in the name of cost saving. Recently, however, global sourcing seems to be on the reverse gear, with local sourcing gaining momentum among OEMs globally.

Localisation brings cost-savings across the supply chain, especially in light of climbing costs in traditionally low-cost regions. According to a study by BCG, manufacturing costs in previously low cost sourcing locations like China, Latin America and Eastern Europe that for many years attracted global vehicle manufacturers, are reaching parity with manufacturing costs in developed countries, once productivity, energy prices and currency conversions are factored in.

At the same time, the advantages of a closer supplier location are clear-cut. First and foremost, it helps minimise the vulnerabilities and logistics costs associated with long supply chains. Moreover, the distance from which components are sourced impacts the inventory that an OEM needs to

maintain. In cases of critical parts, the supply chain is required to carry extra inventory to meet unaccounted demand fluctuations as well as a buffer for delays and disruptions. In addition to blocking resources, large inventories cost OEMs time and money in cases where quality issues emerge in stocks.

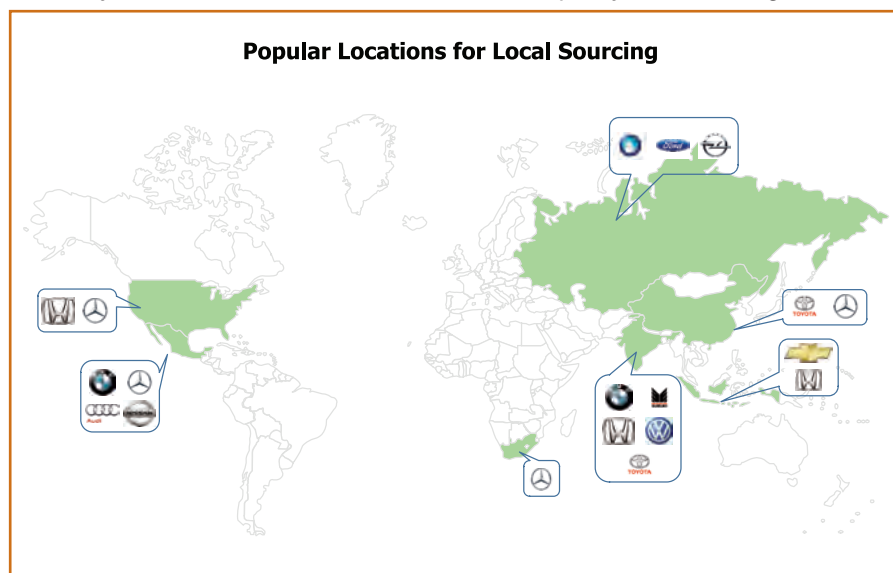



Harald Krüger, member of the BMW AG Board of Management, responsible for Production, together with Mexican President Enrique Peña Nieto at the announcement of the plant in Mexico

In some cases, OEMs consciously take a decision to source locally to meet local content quotas. They also manage to avoid currency fluctuation risks and save on taxes and import duties by engaging in-country suppliers. Thus, OEMs work with local suppliers for supply chain flexibility, as well as the currency and tax benefits they provide, and these advantages increasingly outweigh the pure production cost benefits (of global sourcing) that once attracted OEMs.

This phenomenon of local sourcing is being witnessed across the globe, with leading OEMs sourcing locally from developed as well as emerging countries.

India

When looking to shift to local sourcing, several OEM players are focusing on India. Offering a blend of low production costs along with leaner supply chains, implementing in-country sourcing in India seems like a win-win situation.

The latest to join the bandwagon, in February 2015, was BMW. The company has expressed plans to start procuring components locally from about seven India-based automotive suppliers, one of which (Pune-based Force Motors), has been a long-time supplier to its direct competitor, Mercedes-Benz. The car manufacturer's local arm is looking to source engines and gearboxes, door panels and wiring harnesses, exhaust systems, heating, ventilation, air-conditioning and cooling modules, and seats from local Indian suppliers.

BMW, which has been selling partly assembled (completely knocked-down) units or fully imported (completely built) units in India since 2007, is looking to increase the level of localisation from 20% to 50%. In addition to bringing direct savings on taxes, the localisation process is expected to give a push to the company's servicing business, which was earlier dependent on procuring parts from overseas.

On similar lines, another German OEM, Volkswagen, is looking to increase its level of localisation in India to 90% over the next five to six years. The company wants to achieve this by locally producing engines used in VW cars (currently 100% imported). At present, the OEM's Pune plant supply chain is 79% localised in India, with 11% of parts being procured from China and the remaining 10% from the rest of the world.

One of India's leading OEM players, Maruti Suzuki, also aims to reduce imports to US\$1.6bn in FY2015 from US\$2.5bn in FY2012, by locally sourcing diesel engines and transmission components. While content sourced from local suppliers makes up about 96% of Maruti's cars, about 30% of this content is imported by suppliers, which are in turn compensated by Maruti for unfavorable currency fluctuations. Thus, the OEM is looking to develop suppliers that produce components locally instead, to avoid currency fluctuations.

Toyota, Honda and Nissan, amongst others, are also working on increasing local sourcing in India to ward off risks associated with currency fluctuation.

Mexico

The local arm of Audi in Mexico plans to procure 90% of its components for its San Jose Chiapa plant, which is expected to manufacture the Q5 crossover, from 2016. The company aims to achieve 65% local value creation at the launch of production so as to qualify for specific free-trade agreements; the levels of localisation





Production of the new Mercedes-Benz C-Class at the East London, South Africa, plant

vary by agreement, with 35% local content required to export duty free to South America, 60% for Europe, 62.5% for the US, and 65% for Japan. Within three years of commencing production, the company aims to reach 90% localisation. In mid-2013, Audi invited 120 Mexican suppliers to a workshop with a key focus on suppliers that manufacture parts with very high investments, including press plants and paint facilities.

BMW and Mercedes-Benz have also contracted to work together to build a network of suppliers for their new factories in Mexico. While Mexico currently lacks an established network of suppliers of components that are suitable for premium vehicles, the two rivals have been working towards establishing technical competencies among their suppliers.

Mercedes-Benz plans to produce compact cars in the Mexico plant with 80% local component sourcing. In addition, to develop local suppliers, the company is encouraging its existing base of suppliers to expand overseas into Mexico.

Indonesia

Indonesia, which is slated as one of the world's most lucrative new vehicle

markets, is also attracting manufacturers to establish local suppliers.

Honda, which has entered Indonesia's 'Low Cost Green Car' market with its Brio Satya, has strongly focused on sourcing locally. The company uses 85% locally sourced components for the car.

Russia

Several OEM players present in Russia are looking to increase their local sourcing levels, primarily to offset the ongoing currency weakening. Opel, which has seen a significant drop in sales in Russia (owing to low local demand and western sanctions), is looking at increasing its locally sourced content to 60% to reduce its dependence on imported components from the Euro Zone, and in turn contain costs.

Similarly, China's Geely has also entered a restructuring process in Russia, which entails stepping up local sourcing as well as raising prices to offset currency depreciation. While the level of local components used in cars built in Russia stood at about 25% in 2014, this level is expected to increase to 30-35% by 2016, primarily in an attempt to cut costs.

A final word

Owing to its inherent benefits, the trend of sourcing locally seems to have found its ground among leading vehicle manufacturers across the globe, especially at a time when sales remain relatively muted. Leading OEMs are looking to achieve localisation by partnering with local players and by encouraging their existing suppliers to set up plants in these geographies.

Mercedes-Benz has made increased localisation a part of its 2020 growth strategy. The company, which has commenced the production of its new C-Class model in the US, China, and South Africa, has achieved 60% localisation in the US and China, and aims to reach its target level soon in South Africa.

Local sourcing, in effect, is a win-win situation for automotive OEMs and local economies. While these economies are likely to lose revenues from import duties, they are not complaining as it will boost the countries' automotive supplier industry and help in job creation across the value chain. The only losers in the entire picture might be the third party logistics providers, which could see their automotive parts-related business contract, as the distances are reduced between component suppliers and manufacturing plants.

ArcelorMittal believes it can ‘steel’ a lead over new powertrain developments

The world's largest steel manufacturer says it can cut sufficient weight using steel to help OEMs close the powertrain gap and meet future emissions targets

By **David Isaiah**

The push for lower greenhouse gas emissions has resulted in strict standards for vehicular emissions and the need for significant gains in fuel efficiency. These stringent norms have highlighted the importance of vehicle lightweighting, with new lightweight materials like aluminium, carbon fibre composites and plastics competing with conventional materials like steel for a piece of the automotive pie.

Some vehicle manufacturers are trying out vehicles that feature a significant quantity of aluminium, while others are exploring the possibility of using carbon fibre reinforced plastics in their vehicles. With these materials eating into a vehicle's share of steel, manufacturers of steel have upped the ante and have come out with new grades of steel that are both strong and light.

The race is on to find out the best and most efficient way to reduce vehicle weight, without compromising on the economics. Steel, through these newer grades of advanced high-strength steels (AHSS), has made a strong comeback, being able to offer weight reduction without the need for major investments in infrastructure.

ArcelorMittal, the world's largest steel manufacturer, has been at the forefront of technological developments with regard to new types of steel. According to Dr Blake Zuidema, Director Automotive Product Applications at ArcelorMittal, there has been an exponential growth in the number of grades of steel that are being used to achieve weight reduction in cars. From a handful of grades in the 1960s, there are now more than 200, and that number keeps growing. Although the challenges have increased, developments in steel technology have kept pace, he says.

ArcelorMittal, for instance, has put considerable emphasis on understanding the whole body structure design process. The company has CAD studios and FDA models and essentially all of the same design and analysis tools that a car manufacturer has to design body structures. In fact, ArcelorMittal is itself engaged in the design of body structure systems.

"That has given us a very clear understanding of how the properties of our steel interact both with the manufacturing process as well as the final vehicle performance. And that

allows us now to understand which specific mechanical properties or steel attributes are needed for maximum weight reduction and performance in every different part of the automobile," Zuidema explains to *Megatrends*.

One of the reasons for the emergence of so many new steel grades is that virtually every part in a car has a different optimum combination of properties. ArcelorMittal says that understanding the design has enabled it to target these properties and is now driving its product development.

The steel supplier also focuses on the relationships between powertrain improvements, weight reduction and fuel economy, in order to understand the levels of weight reduction required to meet future fuel economy standards. Steel, it says, possesses sufficient weight reduction potential to close the powertrain gap and help OEMs meet future fuel economy targets.

"We've put considerable effort into understanding the role of weight reduction and how much weight reduction is required. And our research, even today, continues to show that the weight reduction we can get from steel is adequate to close the powertrain gap. It can get vehicles to their future fuel economy standards, and it not only gets us there but it gets us there at a lower cost, and with a lower carbon footprint than if you tried to do it with some of the other competing materials," says Zuidema.

Despite the many well-publicised advantages of steel, certain OEMs are looking to increasing use of aluminium, even if it means major investments to retool facilities. One question that crops up is whether, in moving towards more sophisticated high-strength steels, the steel industry has pushed up the cost of steel closer to aluminium.

Not so, says Zuidema. Even though higher strength steels are more sophisticated and therefore more expensive per tonne, in most cases the weight reduction means that less material is required, thus offsetting the higher cost per tonne. In the end, the advanced steel solutions are only marginally more costly than some of the base line solutions.

"Almost all of these grades work very well with the existing manufacturing base, meaning that automakers don't have to invest millions if not billions of



"Our research continues to show that the weight reduction we can get from steel is adequate to close the powertrain gap" - Dr Blake Zuidema

dollars in changing their manufacturing plants to be able to use these new materials. And for the consumer, steel, physically, is easier to repair and, therefore, the consumer is going to see lower repair and insurance costs with steel. So, steel has a clear cost advantage over these other materials," he says.

An increasing interest in electric vehicles means an increasing need for lighter materials. However, rather than developing steel grades specifically for battery electric vehicles, the focus at ArcelorMittal is on understanding the design challenges and using the right grades of steel in the right applications. For instance, some parts of the car need to be very high strength; other parts need to absorb energy in the event of a crash. Other parts, such as exterior sheet metal, merely need to look good and not dent.

Battery electric vehicles present certain unique challenges, says Zuidema. "There is a huge need to protect the battery during a crash event, just like we have to protect the fuel tank in a conventional vehicle. Given the space a battery takes up, it also can be used as a structural element in the car. So we spend a lot of time looking at battery packaging, protecting it and using the protection cage as a structural part.

"Battery electric vehicles tend to weigh more than their gasoline engine counterparts," he adds, "largely because of the weight of the batteries,



S-in motion demonstrator showing ArcelorMittal's automotive steel solutions

carbon into the environment. As long as the standards are set such that the low carbon emissions materials can be used, we will ensure we have a lowest overall life cycle emission...What we don't want to do is create an unbearable task for both the material provider and the car maker. It has to be fair, it has to be manageable, but in the end it has to protect the environment," says Zuidema.

With so much emphasis on advanced high-strength steels, will there be a place for mild and conventional steels in the vehicle of the future? There will, says Zuidema, for the simple reason that there are a number of parts in the vehicle structure that are already at their stiffness limit. Unless a higher modulus steel is developed, the automotive manufacturing industry will continue to use lower strength steel grades in stiffness-critical applications.

Looking to the future, Zuidema says he believes that design insights will drive the product development cycle, something which could result in a whole new series of steel grades. Also likely are higher strength outer panels, which will allow for a thinner gauge. The challenge here is to reduce the gauge of the steel without creating NVH problems. Zuidema reveals that the company is also working on composite solutions, by way of composite patches, to address noise vibration and harshness concerns.

and so things like managing the front and rear crash loads are more difficult. Managing the roof crush in rollover is quite a bit more difficult."

On the matter of emissions regulations, many steel manufacturers and organisations have suggested the implementation of norms based on total life cycle analysis (LCA) rather than just tailpipe emissions. They believe that there is a danger of reducing tailpipe emissions in the use phase, but creating a bigger carbon footprint overall. One approach could

be to set a standard that can be achieved with a low overall emissions technology. Another way would be to allow vehicle manufacturers to take credit for a vehicle which is low in its use phase emissions but is also very low from an overall life cycle.

There are numerous possible approaches, says Zuidema. "For example, we would not want to set the standard so high that it could only be met with a carbon fibre car that would end up creating a much greater carbon footprint. All you end up doing is putting more



You don't know what the vehicle of tomorrow will look like. **But it will always be made with steel.**



Steel: driven by design

We are continually reinventing steel's possibilities. Our smart steel solutions, including Usibor® and Martinsite®, give automakers the freedom to create the vehicles their customers want. Together, we hit targets for fuel efficiency without compromising on safety, style or affordability, and with the lowest possible carbon footprint.

automotive.arcelormittal.com | usa.arcelormittal.com | [@ArcelorMittalUS](https://twitter.com/ArcelorMittalUS)





Welcome to the hot zone

Now there is a plastic that can take the heat. Up to 260°C. Diablo technology is giving engine designers a lighter, more flexible way to create components for efficient cars. **Let's talk about creating tomorrow's engines today.**

Stanyl® Diablo | Akulon® Diablo

www.dsm.com/hotzone

HEALTH • NUTRITION • MATERIALS





Under the hood, says DSM, there's a great future in plastics

*The use of plastics in automotive powertrain applications is set to grow, as **David Isaiah** discovers*

In the period between now and 2020, the automotive industry is expecting to see considerable change in the use of plastics in automotive applications. A study published by Grand View Research shows powertrain applications as the fastest growth area for automotive plastics during this period, with a forecast CAGR of 10.4%. Overall, says the report, global automotive plastics demand is expected to reach 14,851 kilotonnes by 2020.

DSM Engineering Plastics, headquartered in the Netherlands, has been working with the automotive industry to design lighter, safer and greener components. *Megatrends* asked Bob Akins, the company's Vice President – Marketing & Sales, and Glenn Cannavo, Automotive OEM Manager, about the capabilities of plastics in automotive under-the-hood applications.

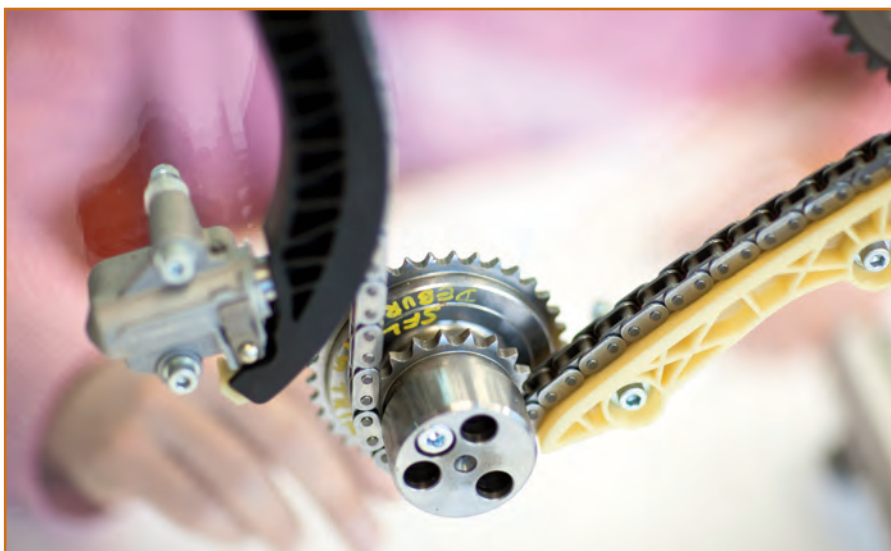

DSM anticipates considerable growth in the use of plastics in powertrain applications

The use of plastics in automotive powertrain applications is set to enjoy considerable growth over the next few years. What lies behind this growth?

Overall, the plastics segment in powertrain is a growth segment, based on the need to improve fuel efficiency and reduce mass. Our high temperature materials, and our high



Why make it out of metal when you can make it out of plastic?

friction materials were what initially led us to focus on powertrain.

One of the key issues in powertrain is chemical resistance, which is what all our products deliver. Our customers are looking for applications at 150 degrees Celsius, on a continuous basis. If you look at our product line, we fit that space. And we know that they're increasing that requirement as well, approaching, in some cases, up to 200 degrees Celsius. Our whole product line of nylon and polyesters fits there very well.

What are some of the ways in which plastics can deliver fuel savings in the powertrain segment?

Well, the driver for fuel economy is taking out mass, which means less moment of inertia. One of the ways of doing this is to take out mass and replace steel or aluminium with a plastic. Additionally, we look at friction reduction. A low coefficient of friction means less inertia is required to move something. Those are two key areas for us.

In addition to fuel economy, another key area is manufacturing. The secondary operations required for machining steel or aluminium are costly compared to manufacturing plastic.

You also talk about cost reduction. How does a vehicle manufacturer save costs when using plastics in the powertrain segment?

We can simplify the cost of manufacturing components, which is

probably what first led to the use of plastic in the automotive industry. Take, for example, an air intake manifold that's cast, machined, and then polished. Many smaller, dimensionally critical components are machined. You can take a piece of aluminium and its material cost is acceptable, but it takes considerable machining – and additional cost – to convert it into a component. We can mould those shapes in plastic without the secondary operations. And this also reduces the number of components. We can consolidate, we can design in complexity and we can eliminate part numbers.

How do plastics compare with other materials in a total lifecycle analysis?

If you look at the whole lifecycle analysis, the amount of energy it takes to produce plastics is one area. We also look at the recyclability, what plastics can be reclaimed and reused, what really is being retained and reused, and the savings over the life of the vehicle. Our analysis shows that the energy cost that could come in higher for plastics is reclaimed during the life of the automobile and the savings that you see in that area.

Can recycled plastics be put back into powertrain products?

Usually, recycled plastics would go into other products. Recyclability depends how well the overall system is set up for recycling. Moving forward, one of the main drivers to make things more

recyclable is having the ability to reclaim components. Once reclaimed, there are many avenues you can take them to be used in other applications. But to have the ability to reclaim them to begin with is where the big challenges lie.

Looking to the future, where do you see the automotive plastics market heading? Where are the growth areas?

From our standpoint, the big growth areas include the powertrain and vehicle electrification; not only electric vehicles themselves, but the many components in the car that are moving to electrically-driven applications. Those are two of the big areas that we continue to focus on, moving forwards.

If you look at engine components, there are certain places where you can take out mass that we're looking at. Engine downsizing and turbocharging are improving fuel economy. Traditionally, those systems were low volume and used a lot of stainless steel. Plastic materials are replacing some of those stainless steel parts as volumes increase. So they're making engines smaller, but some of the components will also switch from stainless steel to plastic composite materials.

We're also working on safety applications. There are several areas in the airbag system where we can use different plastics. Typically these have been metal in the past, but we've been able to convert them to thermoplastics.

Go further on each tank. We know how.

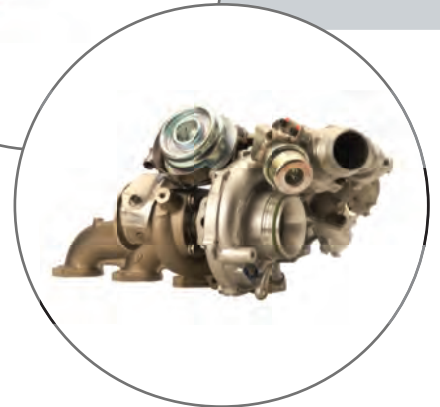
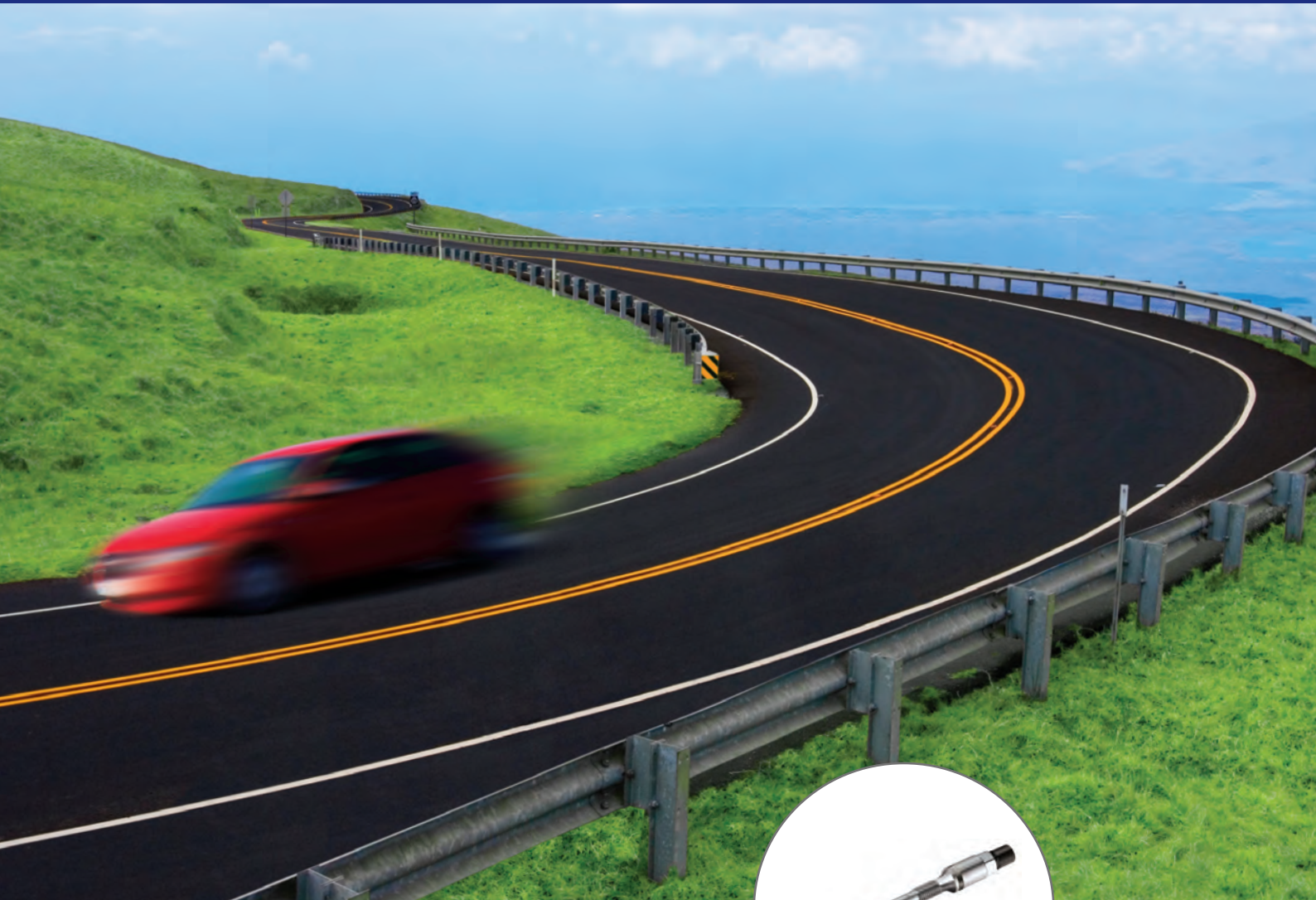

Smaller engines use less fuel and emit lower emissions. But drivers want great performance. BorgWarner knows how to help compact, down-sized engines run more efficiently, reduce emissions and deliver the fun-to-drive experience drivers crave. As a leading automotive supplier of powertrain solutions, we support your engine and drivetrain designers to meet specific challenges and optimize systems. For powertrain innovations that deliver results, partner with BorgWarner.

 **BorgWarner**

feel good about driving

borgwarner.com

Coming
soon!

**The average
car will be
400lbs lighter
by 2025.**

Check out our free guide to
the companies making that happen.

<http://guidetovehiclightweighting.com>

Car ownership makes way for car usership

*Monthly payments are becoming the norm in the automotive industry, and the idea that they may never own a vehicle outright is of little concern to a growing number of car 'buyers', writes **Rupert Pontin**, Head of Valuations at Glass's*

It is not uncommon for the motor industry to create headlines in one form another. There is always a new car that is faster, sleeker, technologically more advanced or more expensive than any other, but once in a while the motor trade also experiences a revolutionary change.

Historically we have seen, amongst other things, the creation of the contract hire and leasing industry as an alternative way for business vehicles to be funded, the introduction of the diesel engine into cars with all the benefits of lower running costs through improved fuel economy, and more recently the development and implementation of a new propulsion system in the form of the electric vehicle, which looks to offer even more favourable running costs and potentially also interesting new business models.

Now we are experiencing a different phenomenon, one that revolves around private vehicle ownership and the way in which consumers want to fund their transport. It is akin to the revelation that was the creation of the contract hire

and leasing industry in the 1970s, and today's Personal Contract Purchase (PCP) agreement allows the customer to offset a large proportion of the upfront cost of the car to the end of a pre-defined contracted period. In doing so, this enables the cost of ownership to be shown in a relatively cheap and easy to accept monthly figure whilst then offering the customer the ability to either buy the car at the end of the term or refinance themselves into a new vehicle via a new PCP deal.

The table below shows exactly how the PCP contract has changed the shape of new car financing over the past few years by representing the % of UK new car sales that are funded using a PCP deal.

The 2015 forecast of 85% of the total of privately registered vehicles being funded by a PCP deal shows not only an increase of 212% over the 2011 figure, but also demonstrates a complete domination of that market sector. The remaining 15% of sales will fall predominantly to the older generation who may be unable and

unwilling to take finance at all, preferring instead to pay outright from their savings.

The question is, why has this change of ownership style come about? There are a number of potential reasons: The key instigator of this behaviour was the recession in 2008/9 and the impact this had on the world economic picture. Consumers have been forced to be very conscious of exactly how and where they spend their money and encouraged to micro manage expenditure to better match their income. As such, the thought of buying a family car at £16,000 or US\$25,000 has become quite a frightening prospect and tends to scare people into thinking they cannot afford to spend that much money. However, quoted as a monthly figure of £299, for example, it becomes both manageable and appealing, and many people even forget that in reality they may never own that vehicle outright.

In addition, the shape of the new car manufacturing industry has also had an effect. With planned growth in production facilities agreed many years in advance, the volume of cars produced is set some years before they actually hit the road. Therefore, the drop in value of the European economies and European car markets has posed a problem for the increases in sales volumes forecast seven to ten years ago - and the legacy sits with us today. The UK has proven to be the only truly robust European market for sales success, facilitating the consistent growth in new car market sales figures. Of course, it also helps that as a society we have become accustomed

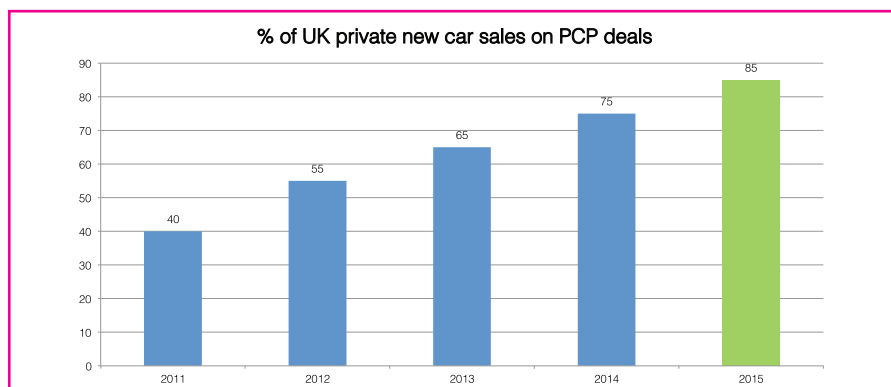

Source: Glass Editorial Research Team



to paying for almost everything on a monthly basis. From home energy and credit cards to cell phones, it is rare that anyone pays a full bill every month, preferring instead to opt for the standard monthly direct debit route that allows clear and simple fund management, often whilst masking the true cost of daily life. Why not add a car to the monthly figures? The key fact here is that with every day that passes, it is this younger 'direct debit generation' that makes up more of the buying power in many markets worldwide. These are the people that now accept home ownership to be something they will perhaps neither achieve nor desire, and that the concept of outright ownership of anything other than personal effects is neither important nor necessary in life.

The other important factor is that today's younger buyer seems to have less interest in what they drive. The focus is so strongly on cost that whether they choose a Hyundai over a Kia or a Ford is becoming almost entirely mathematical. Many younger buyers take the view that most cars look the almost the same and will drive to similar and acceptable standards, and as such the purchase process is becoming less emotional and very much more financial - in other words, how it meets their monthly budget. Whilst this is largely anecdotal and relates specifically to the younger buyer of small cars at the moment, it is an important factor for manufacturers and finance companies to consider when looking at the future of vehicle design and marketing. The introduction of car 'shops' similar to the one recently



Hyundai Rockar, Bluewater

opened by Hyundai in the Bluewater shopping centre in the south of England is an indicator that touching and driving a car before buying it is less important now; the rest of the market could well head in this direction in the coming years.

Also worthy of consideration is the way in which the company car sector is changing. In these days of increased taxation, the company car driver – in the UK, at least – is continually hit with greater costs for what in many cases is a benefit in kind. This is beginning to become less cost effective for those with low business mileage and minimal company use for their business-owned vehicle. Equally, companies are always looking for ways in which to cut costs, and it is becoming more common for employees to be offered a cash-for-car payment or similar incentive to give up their vehicles. There is also a trend for fleet managers and human resources departments to look at offering a mobility allowance for the employee to manage on a monthly basis to make

sure that they have a choice in how they travel. For city dwellers, this allows the flexibility of taking a smaller car on a PCP deal or looking at car rental for instances where there is a need to use a car. It also allows the choice of entry-level motoring or premium comfort, with the key factor being that this will be a monthly allowance offering ownership flexibility to the business user, effectively turning them into a retail consumer focussed on a monthly expenditure.

In summary, it is clear that today's younger generation is helping to change the shape of the new car market by welcoming the arrival of monthly payments for a large ticket item they will never own. This should not come as a surprise, as it has been evident elsewhere in the world in recent years. Equally, we should not be concerned but rather learn to embrace the challenges and benefits this will bring to retailing new and used cars, and valuing an asset that may be three years old before it is truly owned by a consumer.

Technology sharing spreads to retail



*Avi Steinlauf, Chief Executive of Edmunds.com, addresses the benefits of making CarCode free for all car dealers, as well as the potential for the technology moving forward. By **Megan Lampinen***

Technology sharing is making its way into the retail sector with the announcement from Edmunds.com that it will make its CarCode texting tool available for free for all car dealers. *Megatrends* spoke to Edmunds.com's Chief Executive, Avi Steinlauf, on the move and the potential for the technology moving forward.

CarCode is a cloud-based SMS texting platform designed specifically for the needs of car dealerships. It allows dealers to receive texts from customers and respond directly from their mobile phones. So far, the response from dealers has been positive. "It's still early days, but we are getting thousands of sign-ups and many inquiries from dealers about whether they can use the platform for service updates and other types of communications with customers," explained Steinlauf. "The answer to that is of course 'yes' and we are enthusiastic about all the manifestations of the CarCode platform that will have their place in a world increasingly focused on texting."

Text messaging is becoming a popular means of communication between dealers and customers. Velocity research has shown that dealers who send three or more text messages after making initial contact with a buyer can increase conversion rates by 328%. According to research from Edmunds.com, at least one-third of all

car shoppers said that they prefer to contact a car dealer via text message, as opposed to phone or e-mail.

"Texting has taken off around the globe and the US may not be in the lead in terms of texting applications. That form of communication that doesn't require a lot of infrastructure so it has become universal," observed Steinlauf.

For dealers, it offers greater opportunities in terms of maintaining relationships. "Dealers are interested in communicating with shoppers wherever they are, and more and more people are gravitating toward texting as a primary form of communication," he said. "It's in dealers' best interest to make sure that they are there, and, with our free offering of Edmunds.com CarCode, we've made it very easy for them to get there."

Free for all

Edmunds.com's decision to share the technology that it developed follows similar announcements from the automotive industry. Tesla announced last June that it would make its hundreds of patents freely available as part of efforts to encourage EV development and interest. More recently, Toyota said it would similarly make its 5,600 fuel cell-related patents available for use, royalty free, by other companies.

"In today's business world, we see a lot of valuable assets being made available for free," commented Steinlauf. "It makes sense for each of the companies involved, especially the leaders among us, because we each want to see our technology become pervasive. Toyota is sharing its R&D around hydrogen, wanting to make a big play so that the rising tide will lift their boat."

At Edmunds.com, Steinlauf pointed out that the company has offered its information and services without charge from the early days of the Internet when it went online in 1994. "Now, we not only allow car shoppers and others to access our data on our free website, but also we make essentially all of our vehicle data available through our API. We have been on the cutting edge, and already are seeing others follow our lead," he added. "This accessibility and leadership has bolstered our prominence in the space. Sharing CarCode for free is consistent with our long-standing strategy and brand image. We want CarCode to be the preeminent platform through which dealers and car shoppers text each other. This is a great opportunity to provide a needed service from a leadership position, and we've gotten a great reception from thousands of dealers already."



Whose data is it anyway?

*The tide is turning in the struggle between OEMs and independent garages over access to vehicle data, but there's still a long way to go, writes **Stuart James**, Director of the UK's Independent Garage Association*

The Ricardo report on access to vehicle repair and maintenance information (RMI) commissioned by the EU was published at the end of 2014. The findings, based on 'real world' experiences of independent operators, confirmed the long held view of trade bodies that although the levels of access to information, training and equipment are improving, "certain obstacles are still apparent to varying

degrees depending on the OEM". As a result, there is still some way to go to achieve "non-discriminatory" access to information across the EU.

The right of access to information for independent operators was originally defined in principle under the "Block Exemption" regulations of 2002 and refined by the "Euro 5" regulations in 2007. However, although the consumer

now has a legally defined freedom of choice in his selection of a garage to service and repair his car, that garage still faces a number of restrictions in its ability to do so.

One of the major problems identified by the Ricardo report is that there is a "wide variation in user interfaces and software compatibility for OEM websites" which means that



However, there may be good news on the horizon for independent operators in Europe as the continued delays in standardising access to information have led to efforts to achieve the same thing by third party means. In this respect, the Euro-DFT project appears promising. As well as a single PC solution to access various manufacturer websites for information, it provides a new VCI (Vehicle Communications Interface) that achieves 100% compatibility with the manufacturer's communication with the vehicle - across a number of vehicle brands. Work is under way to extend the number of vehicle brands which are compatible with the system.

As well as assessing the current situation, the Ricardo report looks forward in respect of both monitoring the ongoing compliance by the manufacturers, and keeps a weather eye on the introduction of new technologies such as telematics which fundamentally change the relationship between the manufacturer of a vehicle and its owner. The principle of non-discriminatory access to information for the independent operator must apply whatever the communication method with the vehicle itself, and the "privileged access" to the driver that the manufacturer will enjoy must not be used to reduce consumer choice in the arena of service and repair.



standardises access to repair and maintenance information, will address many of the issues. However, manufacturers responding to the survey reported an implementation time of around three years to be fully compliant. This means that it will not be before 2018 that principles laid down in 2002 will turn into reality for independent operators in Europe.

These differences in interfaces and software provide a particular challenge to independent operators who may need to access many different manufacturer websites during a working week – and currently there is no easy way to do this with a single PC. This is one reason why third party data suppliers are popular with independent garages, as their interface is consistent across brands, even if their coverage is incomplete. Even after information is accessed, there is no single third party diagnostic device which can provide manufacturer levels of access to the vehicle for all the brands likely to be encountered in the independent garage.

There is some good news for independent operators in Europe: ISO 18541 does more than simply standardise the access to RMI, it also describes the SERMI (SEcurity related Repair and Maintenance Information) scheme which provides for the accreditation, approval and authorisation of independent operators to allow those that meet the rightly stringent integrity requirements to have access to all areas of a vehicle's systems, including security. It is possible that the SERMI standard will be formally adopted in the second quarter of 2015 and RMI Standards and Certification in the UK is poised to be in the vanguard of European bodies accrediting independent operators to the SERMI scheme under ISO 18541.

There's still a long way to go until independent operators can truly provide multi-brand service and repair to consumers in the EU – but with changes set to occur in 2015, that time is beginning to get considerably closer.

"independent operators have had difficulties in accessing information – yet most of the OEMs interviewed firmly believe they fully comply with the requirements of the Regulations."

The report acknowledges that the introduction of ISO 18541, which



Driving in-vehicle innovation with the Internet of Things.

Learn more at
intel.com/automotive

A light blue sedan is shown driving on a multi-lane highway. The car is in the foreground, moving towards the viewer. The background shows other vehicles and greenery, all slightly blurred to convey a sense of motion. The sky is clear and bright.

It's only natural for our digital, connected lives to extend to our cars to make our rides safer and more enjoyable. Intel is setting the wheels in motion by partnering with the automotive industry. We are using our technology and expertise, and investing in research and ecosystem alignment, to accelerate the development of innovative, unique experiences from the car to the cloud.



You've got to compute to commute, says Intel

Intel discusses its part in the ADAS rollout. By **Rachel Boagey**

Advanced Driver Assistance Systems (ADAS) are the basis for not only intelligent driving but automated driving. The application of ADAS in cars can significantly reduce the severity of injuries, as well as preventing many crashes altogether. With nearly three-quarters of 2014 vehicles offering blind-spot detection and half offering lane-departure

warning as options, it is clear that driver assistance technologies are cascading across vehicle lines and becoming more mainstream, and will only continue to do so going forward.

There is no denying that it will take considerable computer muscle to power next-generation ADAS technology, meaning that bringing

ADAS into the automotive industry is not easy. In fact, around 1Gbps of data will need to be processed in the vehicle's real-time operating system, and that data will need to be analysed fast enough to allow the car to react to changes in less than a second.

At Intel, the Transportation Solutions Division is looking specifically at how technology and automotive expertise can come together to create the car of the future. Sam La Magna, Director of Advanced Driving Technologies at Intel, told *Megatrends* about the next generation of ADAS capabilities, and what role the company can play as this technology unfolds.

Innovation and investment

La Magna describes the car as "one of the most significant, interesting computing devices that can be connected to the rest of the world," and believes the majority of the innovation that will happen in the car over the next five to ten years will take place in its software and the electronics. "Of course, there will still be improvements in the car's mechanics, its aesthetics, and its overall reliability and efficiency," he conceded, but one of the main



"The car is becoming as much compute as it is commute" - Sam La Magna, Intel

areas at which R&D spending is being targeted is connectivity, and in particular ADAS and safety. “The car is really becoming as much compute as it is commute, and the automotive industry will be making continual investments in the IT and consumer electronics world.”

And that’s where Intel comes in. “There is an enormous amount of computer technology well beyond Intel’s microprocessors, including elements of security, connectivity, and manageability. When we look at the car, we don’t look at the microprocessor,” noted La Magna, “we look at the platform and everything from how we can capture data and how we can crunch that data, to how we can use it to get to meaningful actionable data points that will help us make the car situationally aware, as well as driving it to an elevated state of safety or usability.”

Collaboration with companies outside of the automotive sphere is described by La Magna as an essential part of developing the connected car, which could accelerate the traditionally slow lifecycle of the connected car. “The auto industry has seen the computer industry historically move very, very quickly. There are refresh cycles that are on the cadence of 18 months, and new technologies that emerge every single day, and that’s not traditionally how the automotive industry works,” he explained. “But consumers are

beginning to develop an insatiable appetite for technology in the vehicle, meaning that the industry needs to partner up with other industries to deal with these demands and challenges.”

But it is not just a one way street, and La Magna notes that at the same time, the IT industry is looking at and can learn from automotive, “noting a heightened level of safety, a heightened level of reliability, as well as a heightened level of longevity of products.”

In it to win it?

The accepted thinking in the automotive industry is that the most innovative OEMs will prevail in the connected car race; in any industry there are innovators, fast followers, and laggards.

Interestingly, La Magna believes that in some ways, being a ‘lagger’ is no bad thing when it comes to connected car innovation. The innovators have no rules to follow. “Some OEMs are willing to put themselves out there, and lead the industry in setting standards, or expanding existing standards, and then other companies come in behind them and snap to them.”

ADAS could resolve some of the difficulties faced by multiple parties, such as older and new drivers. For the former, ADAS could extend safe mobility as a driver, and the latter could benefit through driver distraction aids. In fact, La Magna explained that “the two largest demographics of drivers on the road are brand new drivers and senior drivers, and ADAS is helping OEMs to target these age categories by offering them the benefits they want from a car.”

Moore’s Law

One of the most important areas La Magna believes the automotive industry needs to focus on is what is happening inside the cabin. “The state of the driver and his alertness needs to be focussed on just as much as what’s happening outside the car,” he explained. With that in mind, La Magna suggested that Intel can help OEMs implement next-

generation ADAS, “which enables the vehicle to become 360 degree situationally aware.”

Intel therefore provides OEMs with the option to use an array of different sensors, bringing cameras, lidar, radar, and ultrasound into the car. These systems can be integrated from high-end cars all the way through to the lower-end: “We can do that all in a very small footprint, power-optimised, safe way, mainly because of just Moore’s Law. What would have taken a trunkful of servers just two years ago, you can now put in a small box that fits under the driver or passenger seat, which happens to be the safest place in the vehicle.” Moore’s Law is a term first coined by Gordon Moore, co-founder of Intel, regarding the development of integrated circuits, which he described as being at the heart of the modern computer’s ever-improving price performance.

Autonomy is reality, but standards are needed

Far from becoming a reality, self-driving cars are already here, says La Magna. “They may be vehicles on private tracks, but they are here.” He described his experience of sitting in an autonomous car as “a thrill for two minutes, but then I was bored. And I realised, that’s exactly what it’s supposed to be. It’s not thrilling, because it’s doing exactly what it’s supposed to be doing in a very safe way.”

La Magna also explained the need for OEMs to work as a collective for the autonomous car. “I think the industry needs to adopt some standards and work as a group of interested parties to move the technology forward at a rapid rate. They need to come together with the IT industry to help democratise these ADAS capabilities and the delivery of autonomous vehicles. Because that, coupled with an intelligent transportation system, will help ensure that we continue to move people, goods and services safely, economically, and efficiently.”

With the development of next-generation ADAS, the automotive industry is entering an era in which cars will become much safer and more efficient as they grow increasingly aware of and react to their surroundings. “So while you shouldn’t take your hands off the wheel just yet,” concluded La Magna, “you can certainly see what the future holds.”

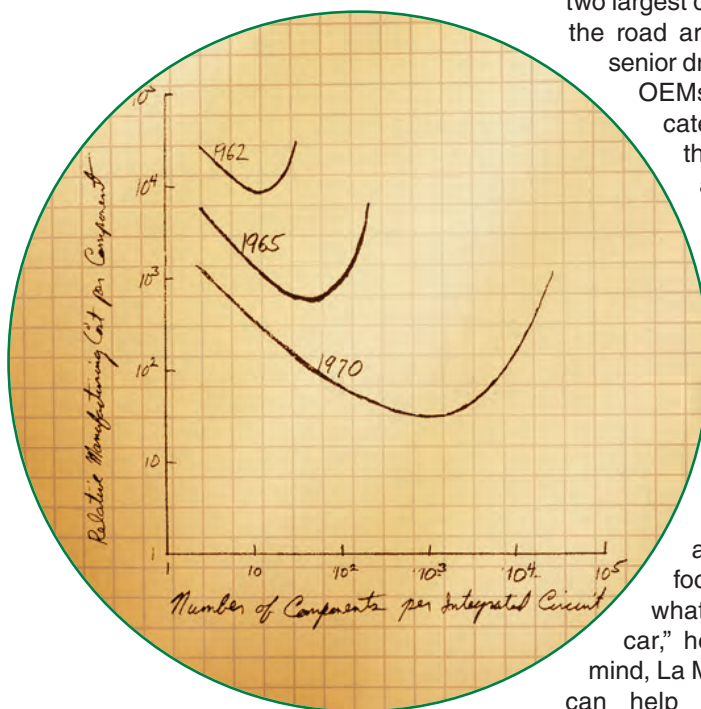

Original sketch (1965) of Moore’s Law by Gordon Moore, co-founder of Intel

India's crash course in car safety

*India finally appears to be heading towards implementing globally-accepted safety standards for crash worthiness. By **David Isaiah***

In India, where economy is the watchword, small cars make up the largest part of the market. To be successful in India's mass volume market, a car must be priced correctly, must be fuel efficient and must be low maintenance, or at least be affordable to maintain. In India, prioritising these parameters has been done at the expense of safety.

With profitability at the top of the agenda, OEMs selling cars in India's highly price-sensitive market have kept prices down by compromising on safety, at least in the basic versions of their cars. Safety features like airbags and ABS are offered, but not as standard fitment.

The crashworthiness of cars in India came to the fore in January 2014, when

the first ever independent crash tests of some of India's most popular cars revealed a high risk of life threatening injuries in road crashes. These tests were carried out by Global New Car Assessment Programme (Global NCAP).

This first round of tests involved some of India's best sellers, like the Maruti Suzuki Alto 800, Hyundai i10, Ford Figo and Volkswagen Polo, along with the country's cheapest car, the Tata Nano. The entry-level version of each of these cars, which is sold without airbags, fared quite poorly in the tests, and in a frontal impact test, received zero-star adult protection ratings.

"India is now a major global market and production centre for small cars, so it is worrying to see levels of safety that are

20 years behind the five-star standards now common in Europe and North America. Poor structural integrity and the absence of airbags are putting the lives of Indian consumers at risk. They have a right to know how safe their vehicles are and to expect the same basic levels of safety as standard as customers in other part of the world," said Global NCAP Chairman, Max Mosley, at the time.

Apart from the Volkswagen Polo and the Ford Figo, the cars also failed when assessed against the UN's basic crash test. This test is currently followed in countries like Australia, China, the EU, Japan and Malaysia, and the UN has recommended that all member states adopt this safety standard. As is obvious from the results, India has yet to adopt this standard.



This, of course, does not mean India manufactures cars that are unsafe; in fact, many cars made in India for export meet these standards, which only goes to show that the country's automotive manufacturing segment already possesses the know-how and the capability to incorporate such safety standards into cars produced for the local market as well.

"India's automobile industry just needs the right incentives. With the UN's minimum safety standards and clear information for consumers, India can produce cars that are every bit as good as those in Europe and the US," said Rohit Baluja, President of India's Institute of Road Traffic Education (IRTE).

Global NCAP's safety expectations for cars in India, and the idea that Indian cars should meet US or European safety standards, did not meet universal approval. Andy Palmer, at the time Nissan's Chief Planning Officer and Executive Vice President, stated that it was 'absurd' to demand that emerging markets adopt European safety standards overnight.

Late 2014 brought more revelations on the level of safety in Indian cars. Global NCAP tested two more cars, the Datsun Go and the popular Maruti Suzuki Swift and published the results in November 2014. The results were more or less the same – 'a high risk of life-threatening injuries with both cars receiving zero-star safety rating for their adult occupant protection.'

By this time, though, the Indian government had woken up to the issue of crash worthiness, and had decided to launch a new car assessment programme. Global NCAP welcomed this step, but suggested that the country move to apply the UN's minimum crash test standards as well.

"We welcome the initiative of the Indian government to launch its own NCAP and recommend that this positive step is combined with the application of the UN regulations for frontal and side impact. Prompt action like this would prevent the introduction of brand new models like the Datsun Go, which has a body structure so weak that it is pointless to fit an airbag," Global NCAP Secretary General David Ward said.

The Datsun Go falls under the mass volume category and falls under the small car segment. When it was launched, the Go had no standard



"The Datsun Go...has a body structure so weak that it is pointless to fit an airbag" - Global NCAP Secretary General David Ward

safety features, apart from seat belts. Enforcing safety and crash worthiness can only be done through legislation and mandatory safety standards.

The Indian government is close to achieving this. By the end of 2014, the decision was made that all new cars will have to pass minimum frontal and side crash tests, starting in October 2017. For new versions of existing models, the deadline will be October 2019. To pass these tests, cars will likely have to feature airbags and other safety features as standard.

The requirements of India's safety assessment programme, Bharat New Vehicle Safety Assessment Programme (BNVSAP), have not yet been published, but to pass the UN frontal impact test, for instance, "all a vehicle needs is a driver's airbag, which is a cost less than US\$100. You also need reasonable body shell strength, which has almost zero cost," Global NCAP's David Ward told us.

Cost is one of the main stumbling blocks for vehicle manufacturers to improve car safety. A common argument used by OEMs is that features such as airbags, ABS and electronic stability control – features which play a crucial safety role – can significantly increase the cost of cars. At a time when the country's passenger car market is only just starting to emerge from a two-year-long slowdown, price hikes are something the industry can ill afford.

In fact, under this proposed safety assessment programme, small cars, including cheaper models such as the Tata Nano or the Datsun Go, will have to be equipped with minimum safety

features, according to the country's Road Transport Minister, Nitin Gadkari. The onus of deciding which safety features and tests should be in place falls on CMVR-TCS, the advisory committee to the Ministry of Road Transport, comprising representatives from various organisations.

One of the representatives of this committee is the Automotive Research Association of India (ARAI). ARAI already provides testing services to the Indian automotive industry and has crash test facilities for frontal, side and low-speed crash tests. With these facilities, ARAI has the capability to conduct full frontal, offset frontal, side and rear crash testing.

While crash tests will be mandatory for vehicle manufacturers in India, OEMs have the option of voluntarily raising safety standards and adopting norms in order to take on star ratings for safety. Beyond any mandatory or government-recommended safety regulations lies the moral responsibility for OEMs to make safe vehicles.

There continues to be opposition to various aspects of the government's decision to make crash tests mandatory, and to the speeds for the frontal and side crash tests, especially for the entry-level small car segment. However, as Global NCAP's Ward told us, there was similar dismissive criticism from vehicle manufacturers in Europe in the 1990s. "We were told at the time that it would be impossible for small cars to ever reach high safety standards. They were wrong then." Global NCAP and its industry partners are doing all they can to ensure that the same dismissive criticism does not prevail in India.

Eyeballing the driver

Seeing Machines plans to take its eye tracking technology out of the mines and on to public roads. **Martin Kahl** takes a closer look



At International CES 2015, Intel's booth featured a Jaguar F-Type. The purpose of its presence on the booth was not, however, to promote the car or to highlight Intel-branded technology, but rather to demonstrate the eye tracking technology installed on the vehicle by Melbourne-headquartered supplier of intelligent sensing technologies, Seeing Machines.

In September 2014, Seeing Machines signed a 15-year strategic alliance with TK Holdings, the US subsidiary of Japanese automotive safety equipment supplier, Takata. The alliance sees the two companies agreeing to further develop driver monitoring technologies, an area on which it has already been working for two years with clients in the mining industry.

At CES, *Megatrends* caught up with Nick Langdale-Smith, Vice President, OEM Relationships, to discuss Seeing Machines' plans to take its eye tracking technology out of the mines and onto public roads.

Why mining? "Because mining has big trucks, big problems and deep pockets," grins Langdale-Smith. The mining industry approached Seeing Machines for its technology, which had been identified as a way to solve some of the major issues faced by companies running mining assets, the key one of which is driver fatigue. "Our technology found a very good match in the mining industry, where we were able to put it in the big yellow mining trucks that turn into unguided missiles when their driver is asleep. Remember, they are 500 tons worth of metal and iron," says Langdale-Smith.

Seeing Machines developed a solution that issues alerts if a driver dozes off at the wheel, using both an audible alert and a seat vibration alert. "And that's allowed our customers in the mining industry to save time, money and lives in accidents." An added benefit was a reduction in running costs, because a fatigued driver is also a bad driver – and a bad driver grinds his wheels against the mine walls. "One of our customers saved 50% on their tyre wear and tear cost in a year by implementing our fatigue solution," says Langdale-Smith. "Those tyres cost up to 200,000 bucks a piece. If you scale that up over their entire global operation, that's a US\$21.9m saving in rubber costs. So we're seeing not only savings through preventing accidents and those final catastrophic events where there's loss of life, but, in an industry that's driven by increasing



Using a dot on a screen, the Seeing Machines demonstrator at CES 2015 showed clearly how its technology can track a driver's line of sight - and that it works even if the driver is wearing sunglasses

productivity, we're able to show improvements in running costs. And we're looking at fuel consumption next."

It's fascinating to hear that such technology has come from mining, an industry which has also been the source of much of the semi-autonomous drive technology in trucking. "It was a sensible place for us to start, because these mining trucks cost many millions of dollars. We can't move directly into series production in automotive, where the price points are so much lower when we're still proving out the technology, so we've been able to create really good partnerships in mining. There is such a large problem with fatigue and such valuable assets that we were able to find considerable value in there for the customer. The return on investment just made sense."

Seeing Machines has proven out the technology in the mining industry, and is now moving into trucking and buses, where it is operating on the Intel Atom platform, explains Langdale-Smith. "We're obviously using some of Intel's core processors in the mining and the transportation industry, so we've got this good relationship with Intel in the aftermarket area of our business."

In terms of a proposed timescale for bringing this to market, Langdale-Smith says the CES Jaguar F-Type demonstrator is merely a concept demonstrator. "It's probably going to be two to four years before you're able to see this Gen 1 driver monitoring technology hit showrooms. But we're going to see it get more and more sophisticated from there. Intel has a phrase called Perceptual Computing. The idea is that the machine can perceive its user, and that is exactly

what we're trying to build here. The car becomes imbued with an intelligence of its driver and is able to make intelligent decisions, alert you more rapidly if it detects something that you should be alerted to, or get out of your way so as not to be a nuisance when it doesn't need to be there."

The decisions regarding specific applications of the Seeing Machines technology are up to the OEM to make, says Langdale-Smith. "At Seeing Machines, we are pursuing aftermarket business in mining and transportation. We see opportunities with commercial road transport operators. But over the last 12 to 24 months we've really been pulled very rapidly by a large number of OEMs into needing a solution for passenger vehicles. And the time is coming, to use the Perceptual Computing phrase again, where we're marrying understanding what's on the outside with the understanding of what's going on inside to make these things smarter and safer."

However, there are many different applications beyond smart alerts that can be supported once there's a camera looking at the driver, including advanced head-up displays, augmented reality and gesture-based interaction. "These are all potential applications that leverage an understanding of the driver's face and eyes, and facial expression. What we are trying to do at Seeing Machines is to be the go-to driver monitoring solution, and to be able to understand as much of the driver and the context that the driver is operating in as possible from a camera or cameras inside a vehicle."

Indeed, Langdale-Smith concedes that mood tracking, already under

development elsewhere, is something his company could potentially be asked to roll out by its automotive customers. "We think there's some interesting information in facial expression tracking. For instance, if someone is yawning, that could signal fatigue. There's also research that suggests the slackening of facial muscles can be a precursor to fatigue. Road rage could be signalled by someone who is really tense. We feel that there's information contained in that signal, and our R&D teams are probably going to start looking at that in more detail as we progress. We're a one-stop shop for tracking everything from the neck up and understanding the human face and eyes."

Longer-term, driver monitoring technology like facial expression recognition and eye tracking could be used to monitor heart rate, says Langdale-Smith. "If you look at certain channels of the image, you can start looking at the blood pumping into and out of the face. Those are the sort of things we're considering looking at in the future that might give us an even better contextual understanding of the driver's fatigue levels, awareness levels, distraction levels and cognitive workload levels. And that's going to allow the machine to change the experience to better serve the driver. If you want to get into real science fiction, you can start talking about pupil dilation. I talked to a performance car company which wanted to do some research into keeping the driver on the edge of their seat at all times by looking at the pupils so that they were constantly dilated. There's a lot of science fiction around that one - but who knows what the future holds?"



INRIX is at the Intersection of Connecting Cars for Smarter Cities

While you can have a connected car without a smart city, you can't have a smart city without the connected car. As Big Data and the Internet of Things changes everything from where people go and what they do to how they get from place to place, one thing is abundantly clear. The future of the automobile and transportation in general will be data driven. INRIX is collaborating with leading automakers and governments worldwide to transform how people and commerce move across the world's transportation networks.

Our vision is simple...empower drivers, inform planning and enhance commerce. Our data driven insight from vehicles, GPS devices, fleets, road sensors and incident sources is fueling a host of new applications that not only empowers drivers but makes our cities work smarter.



Come see our presentation at Automotive Megatrends USA

Session 4: Data Driven: Connecting Cars for Smarter Cities

presented by Mark Pendergrast, Director of Product Management

Where: Salon 4 @ Henry Hotel, Fairlane Plaza, Dearborn, MI

When: 3:30 – 5:00pm • March 17th, 2015

Contact INRIX to learn how we are Connecting Cars for Smarter Cities

busdev@inrix.com | www.INRIX.com